

# KRACHT



Pressure Relief Valves

**SPV, SPVF**

directly-operated

**Construction**

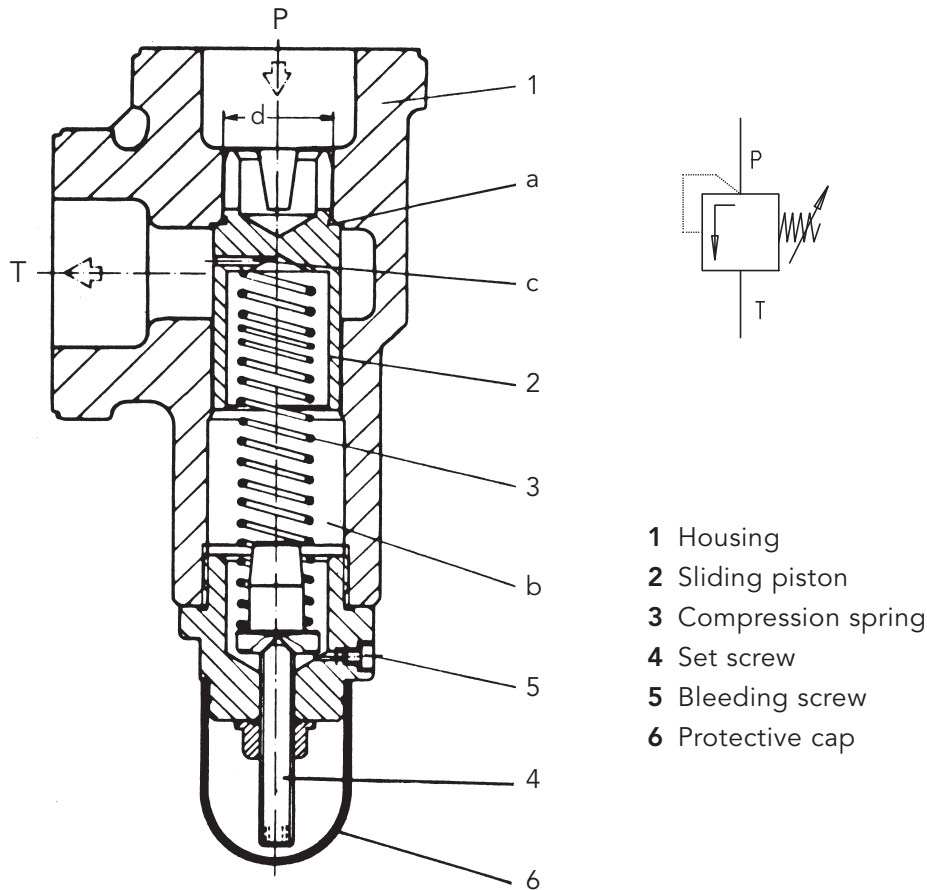

- 1 Housing
- 2 Sliding piston
- 3 Compression spring
- 4 Set screw
- 5 Bleeding screw
- 6 Protective cap

**Description**

The pressure relief valve SPV/SPVF is a direct spring sliding piston valve. It is intended for mounting in pipelines and is suitable to safeguard low pressure hydraulic circuits up to  $p_{max}$  bar 20 (30) bars. The pipe connection is to be effected either by SAE-mounting surfaces (3000 psi) or by Whitworth pipe threads "G".

**Valve Construction**

The sliding piston **2** is pressed against the annulated area **a** by the compression spring **3**. Thus the pump connection **P** is separated from the reservoir connection **T** by sealing the diameter **d**. As soon as the operating pressure **p** is achieved, adjusted by the set screw **4**, the sliding piston **2** releases the oil flow to the reservoir. The spring chamber **b** is pressure compensated by the bore **c**. When starting-up the valve the spring chamber **b** must be bled by the bleeding screw **5**, (hex. socket width: 4). The valve should preferably be installed in vertical fitting position with the **pressure setting arrangement down**.

The pressure relief valves are available in four different pressure setting ranges because, due to their springrates, each of the compression springs can only cover a limited pressure setting range.

## ATEX

### Explosion protection –

#### Field of application for the pressure relief valves.

The valve is used to secure low pressure hydraulic circuits with various flammable and non-flammable fluids.

They can be used:

- a In Zone 2 (Gas-Ex, Category 3 G)  
in the explosion groups IIA, IIB and IIC
- b In Zone 22 (Dust-Ex, Category 3 D)  
in dusts with a minimum ignition energy > 3 mJ
- c In Zone 1 (Gas-Ex, Category 2 G)  
in explosion groups IIA, IIB and IIC
- d In Zone 21 (Dust-Ex, Category 2 D)  
in dusts with a minimum ignition energy > 3 mJ

The qualification for the surface temperature is T4;

for all gases, vapours, mists with an ignition temperature > 135 °C, the operating materials are not an ignition source.

In the Dust-Ex area, 135 °C is the reference temperature for further considerations regarding the safety margin to the glow temperature, etc. (can only be decided by the operating company).

The permissible ambient temperature ranges from  $-20\text{ °C} \leq T_a \leq +60\text{ °C}$ .

#### Marking according to the EU Machine Directive RL 94/9/EU

Manufacturer	KRACHT GmbH D-58791 Werdohl
Type designation	SPV...
Consignment no., Year of manufacture	xxxxxx/xx-xxx xx.xx
Tech. File Ref.	TRR: 04.02X
Protection type marking	⊠ II 2 GD EEx c IIC (T4) or ⊠ II 2 GD EEx c (T4)

**Characteristics**

Product name / Nominal size	SPV = NG 10 SPVF = NG 20 ... 80
Construction	Sliding piston relief valve – directly-operated (Seat on request)
Mounting	In pipeline
Pipe connection	SAE-flange (3000 psi) Whitworth pipe thread G
Dimensions	Pages 7, 9, 10, 11
Weight	Pages 7, 9, 10, 11
Fitting position	Set screw down (preferred)
Housing material	EN-GJL-300 (EN-GJS-400-15)
Type setting	Mechanical Set screw Knob
Accessories	Welding flange SAE (3000 psi) Page 11
$\Delta p$ -Q-Characteristics	Page 5
Hydraulic fluids	Hydraulic oils acc. to DIN 51 524/25 (other fluids on request)

**Hydraulic Characteristics**

Nominal size		10	20/25	32/40	50	80
Max. flow capacity	l/min	40	90	450	550	800
Nom. working pressure	bar	30	25	25	25	20
Pressure setting ranges	$p_{v \min}$	bar	0.5	0.5	0.5	0.5
	$p_{v \max}$	bar	30	25	25	25
Fluid temperature range	$\vartheta_{m \min}$	°C	-20	-20	-20	-20
	$\vartheta_{m \max}$	°C	80 (220)	80 (220)	80 (220)	80 (220)
Ambient temperature	$\vartheta_{u \min}$	°C	-20	-20	-20	-20
	$\vartheta_{u \max}$	°C	60	60	60	60

Viscosity range	$\nu_{\min}$	mm <sup>2</sup> /s	6
	$\nu_{\max}$	mm <sup>2</sup> /s	600 (standard)
	$\nu_{\max}$	mm <sup>2</sup> /s	1500 (possible)
			at $Q_{\max}$ 50 % $Q_N$ and at $p_{\max}$ 75 % $p_N$

**Explosion proof design (ATEX)**

The devices comply with these protective classes:

- ⊗ II 2 GD EEx c IIC (T4) or
- ⊗ II 2 GD EEx C (T4)

**Note:**

Metallic protective cap (cap nut) in ATEX version

Characteristic Curves  $p_E - Q$  Viscosity = 34 mm<sup>2</sup>/s

**SPV 10**

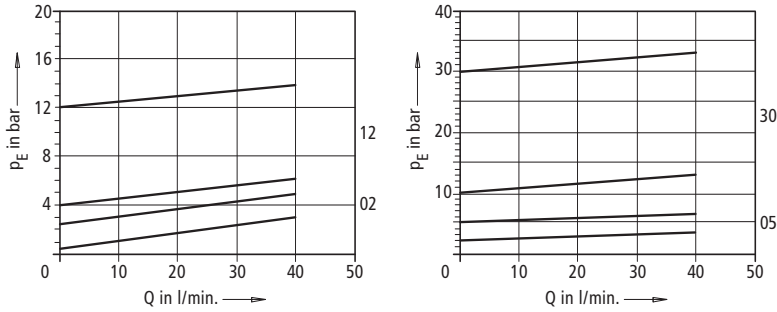

**SPVF 20/25**

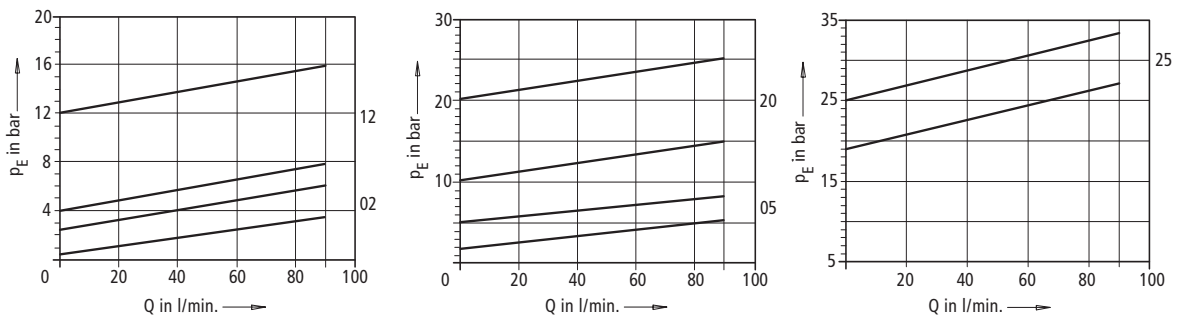

**SPVF 32/40**

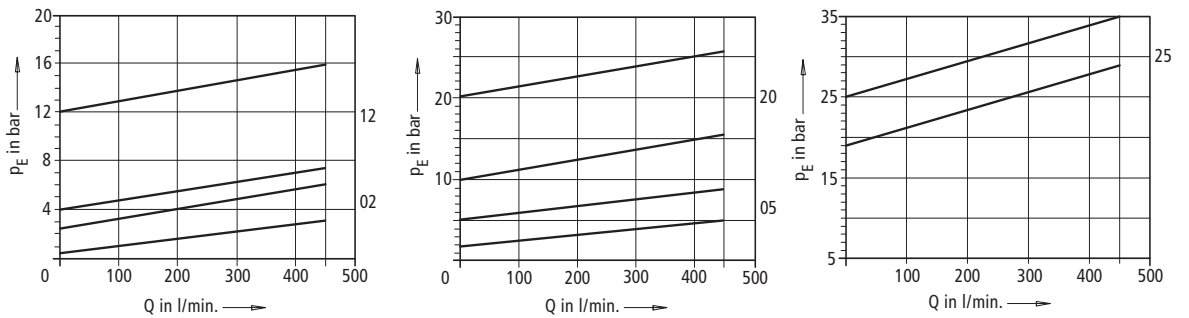

**SPVF 50**

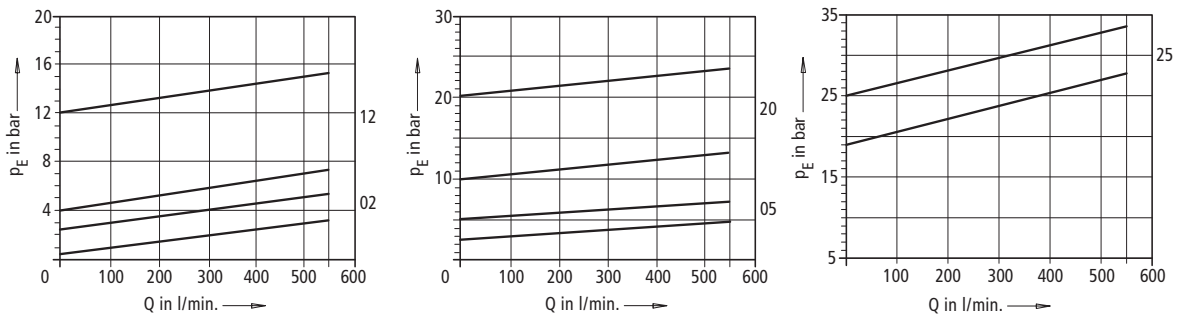

**SPVF 80**

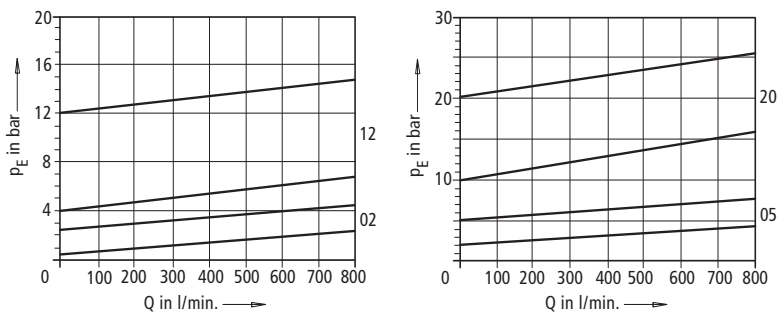

Type Key

Ordering example NG 10

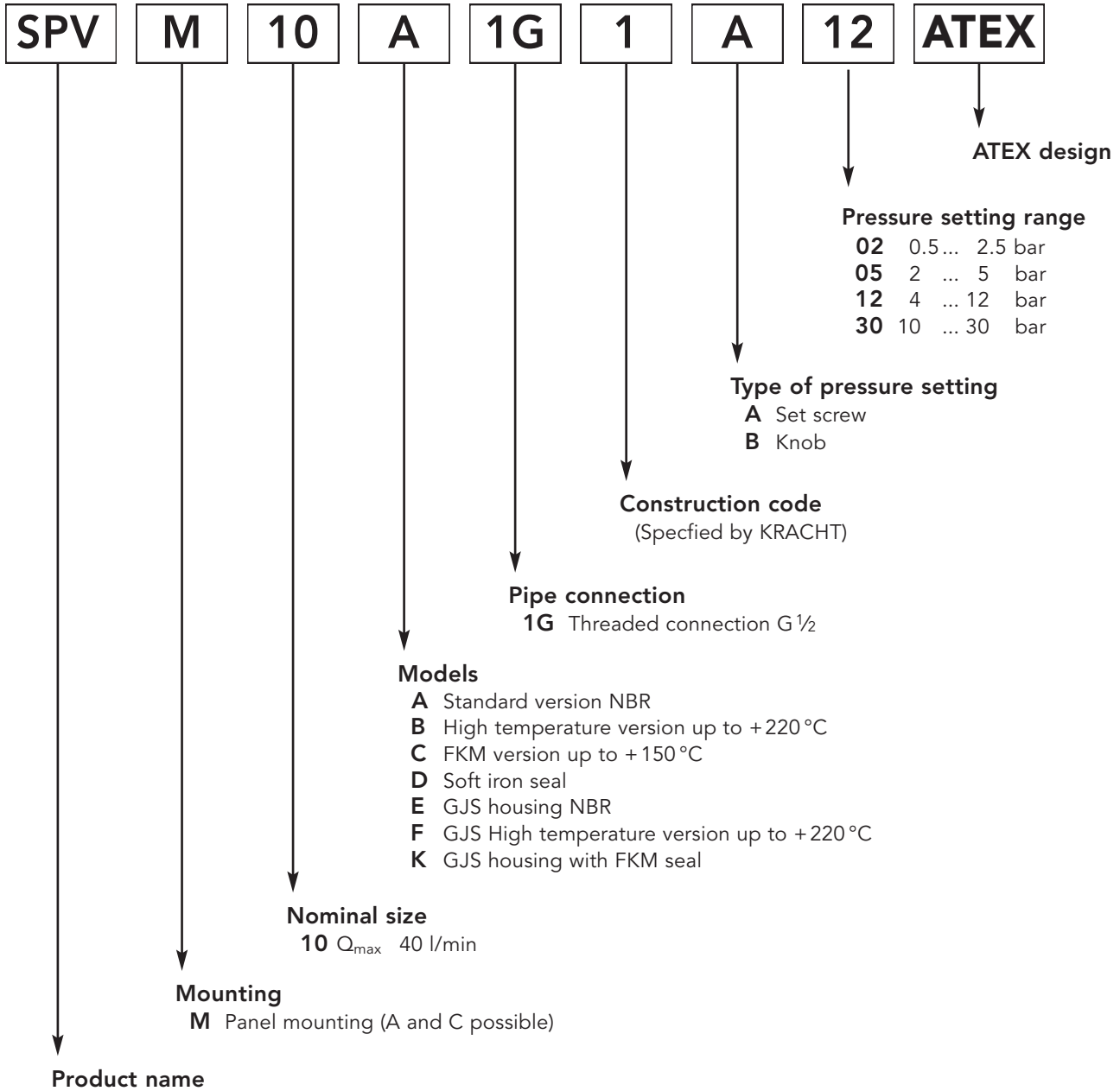

**Ordering example: SPV 10 B 1G 1 A12**

Pressure relief valve, directly spring operated, nominal size 10 (Q<sub>max</sub> 40 l/min), high temperature version (up to +220 °C) with threaded connection G 1/2, pressure setting by set screw, pressure setting range 4 up to 12 bars

**Ordering example: SPVM 10 A 1G 1 B30**

Pressure relief valve, directly spring operated for panel mounting, nominal size 10 (Q<sub>max</sub> 40 l/min), standard version with threaded connection G 1/2, pressure setting by knob, pressure setting range 10 up to 30 bars

**Dimensions** (in mm)

**Ordering codes**

SPV 10 **A**  
**C**  
**E**  
**K** 1G 1 A .

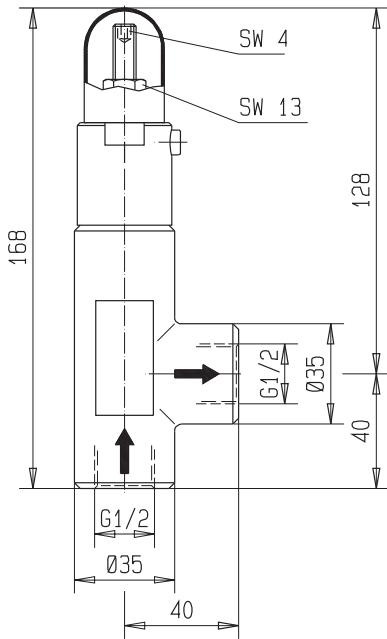

SPV 10 **B**  
**D** 1G 1 A .

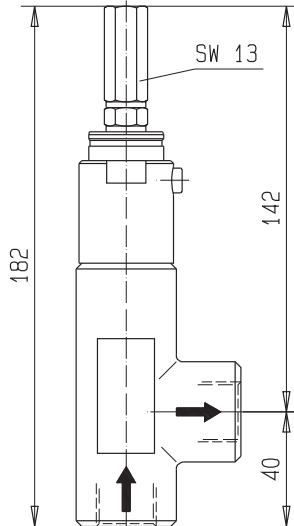

SPVM 10 **A**  
**C**  
**E**  
**K** 1G 1 A .

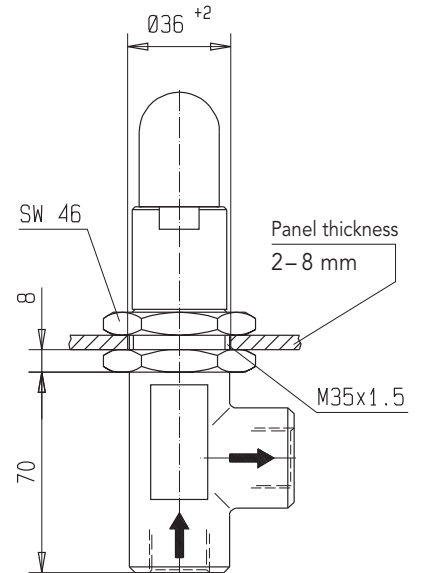

Weight: 0.9 kg

SPV 10 **A**  
**C**  
**E**  
**K** 1G 1 B .

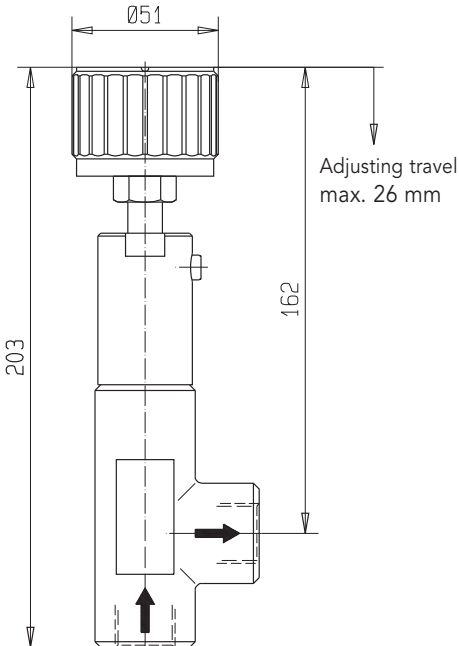

SPVM 10 **A**  
**C**  
**E**  
**K** 1G 1 B .

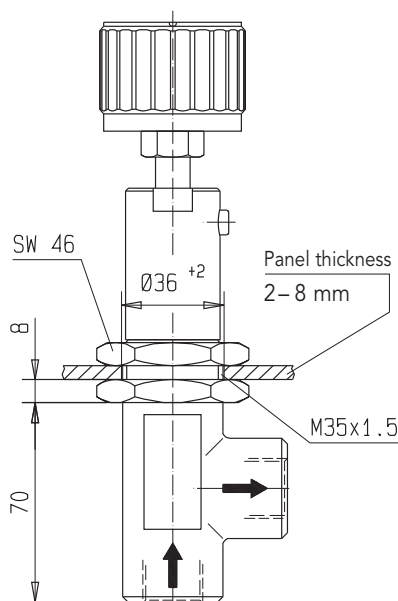

SPV 10 **A**  
**C**  
**E**  
**K** 1G 1 A - ATEX

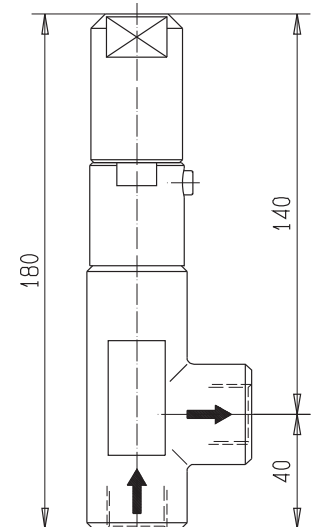

Weight: 0.9 kg

Type Key

Ordering example NG 20... 80

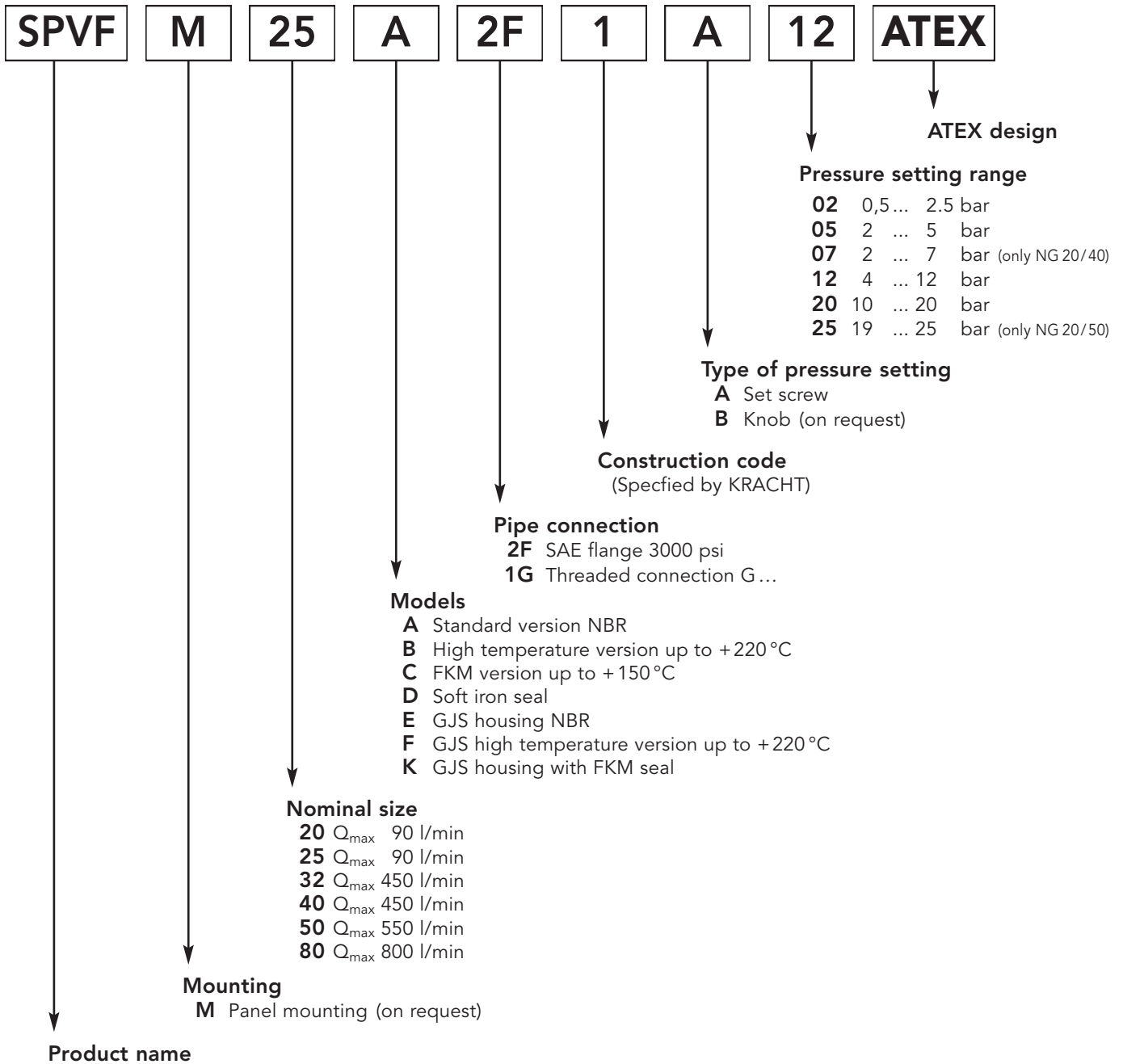

**Ordering example: SPVF 80 A 1G 1 A12**

Pressure relief valve, directly spring operated, flange version, nominal size 80 ( $Q_{max}$  800 l/min), standard version with threaded connection G3, pressure setting by set screw, pressure setting range 4 up to 12 bars

**Ordering example: SPVF 40 B 2F 1 A20**

Pressure relief valve, directly spring operated, flange version, nominal size 40 ( $Q_{max}$  450 l/min), high temperature version up to +220 °C) with SAE mounting surfaces (3000 psi), pressure setting by set screw, pressure setting range 10 up to 20 bars

Dimensions (in mm)

Ordering codes

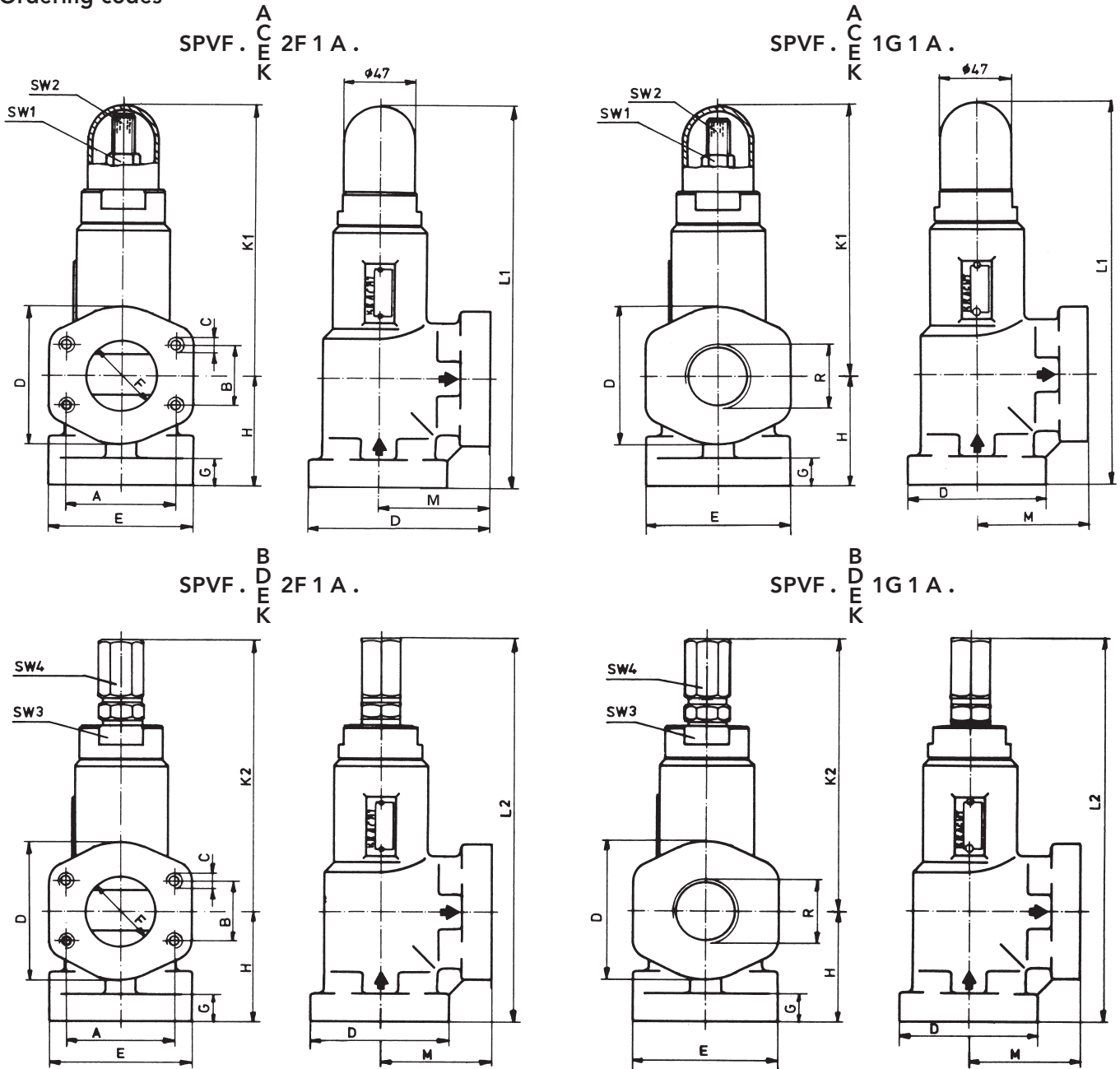

Nom. size	SAE flange	Thread																		Weight kg
			R	A	B	C	D	E	F	G	H	K <sub>1</sub>	K <sub>2</sub>	L <sub>1</sub>	L <sub>2</sub>	M	SW1	SW2	SW3	
20	3/4"	G 3/4	47.6	22.2	M10	59	70	24	20	50	160	167	210	217	50	17	5	46	17	3.0
25	1"	G 1	52.4	26.2	M10	59	70	24	20	50	160	167	210	217	55	17	5	46	17	3.0
32	1 1/4"	G 1 1/4	58.7	30.2	M10	72	79	32	20	65	170	172	235	237	65	17	5	46	17	5.5
40	1 1/2"	G 1 1/2	69.9	35.7	M12	83	94	38	20	65	170	172	235	237	65	17	5	46	17	6.0
50*	2"	G 2	77.8	42.9	M12	97	102	50.5	20	75	192	209	267	284	75	19	6	46	19	8.2
80*	3"	G 3	106.4	61.9	M16	131	135	79	25	110	190	207	300	317	110	19	6	-	19	18.5

\* Housing material spheroidal cast iron

**Dimensions** (in mm)

**Ordering codes**

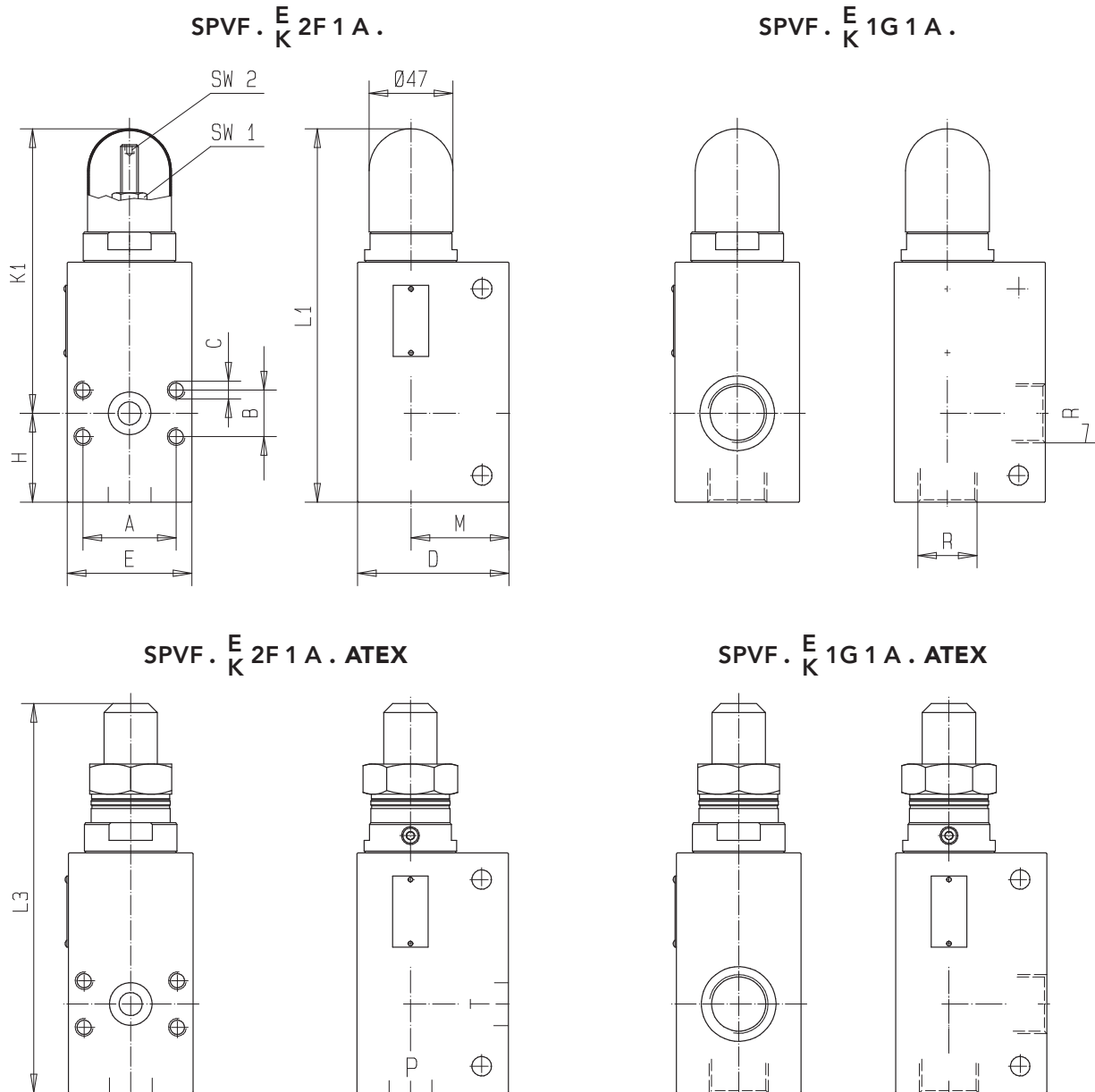

Nom. size	SAE flange	Thread R													Weight				
			A	B	C	D	E	F	H	K <sub>1</sub>	K <sub>2</sub>	L <sub>1</sub>	L <sub>3</sub>	M	SW1	SW2	SW3	SW4	kg
20	3/4"	G 3/4	47.6	22.2	M10	85	70	24	50	160	167	210	219	50	17	5	46	17	3.0
25	1"	G 1	52.4	26.2	M10	85	70	24	50	160	167	210	219	55	17	5	46	17	3.0
32	1 1/4"	G 1 1/4	58.7	30.2	M10	103	79	32	65	170	172	235	231	65	17	5	46	17	5.5
40	1 1/2"	G 1 1/2	69.9	35.7	M12	107	95	38	65	170	172	235	231	65	17	5	46	17	6.0
50*	2"	G 2	77.8	42.9	M12	124	102	50.5	75	192	209	267	274	75	19	6	46	19	8.2
80*	3"	G 3	106.4	61.9	M16	176	135	79	110	190	207	300	307	110	19	6	-	19	18.5

\* Housing material spheroidal cast iron

Accessoires Welding Flange SAE (3000 psi)

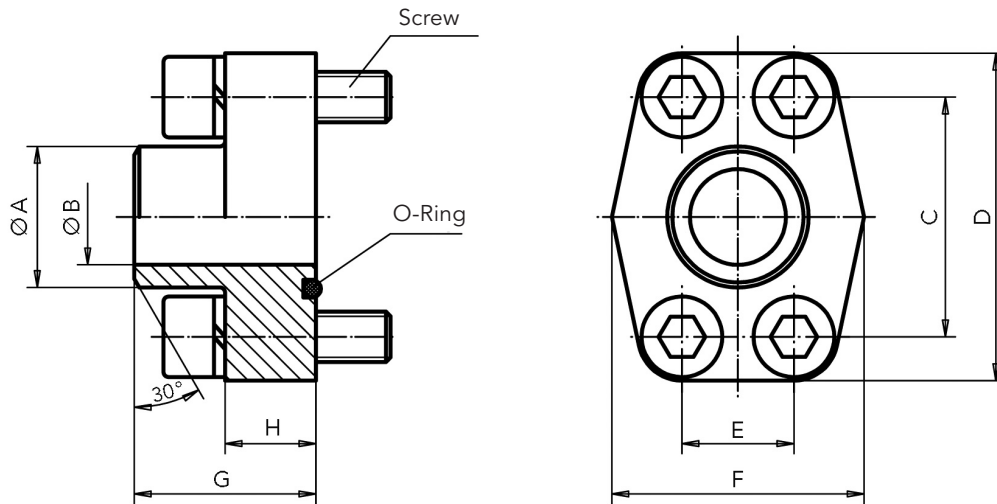

Ordering code	SAE flange									Screws 10.9	O-Ring	max. working pressure bar	Weight kg
		A	B	C	D	E	F	G	H				
B.0195730009	¾"	28.0	19.0	47.63	65	22.23	50	36	18	M10 x 35	24.99 x 3.53 NBR-90	350	0.46
B.0195730012	1"	34.0	25.0	52.37	70	26.19	55	38	18	M10 x 35	32.92 x 3.53 NBR-90	315	0.54
B.0195730029	1¼"	42.8	32.0	58.72	79	30.18	68	41	21	M10 x 40	37.69 x 3.53 NBR-90	250	0.78
B.0195730015	1½"	48.6	38.0	69.85	93	35.71	78	44	25	M12 x 45	47.22 x 3.53 NBR-90	200	1.24
B.0195730003	2"	61.0	51.0	77.77	102	42.88	90	45	25	M12 x 45	56.74 x 3.53 NBR-90	200	1.40
B.0195730020	3"	92.0	73.0	106.38	134	61.93	124	50	27	M16 x 50	85.32 x 3.53 NBR-90	138	2.54

(Dimensions in mm)

# Product Portfolio

## Transfer Pumps

Transfer pumps for lubricating oil supply equipment, low pressure filling and feed systems, dosing and mixing systems.

## Mobile Hydraulics

Single and multistage high pressure gear pumps, hydraulic motors and valves for construction machinery, vehicle-mounted machines.

## Flow Measurement

Gear and turbine flow meters and electronics for volume and flow metering technology in hydraulics, processing and laquering technology.

## Industrial Hydraulics / Test Bench Construction

Cetop directional control and proportional valves, hydraulic cylinders, pressure, quantity and stop valves for pipe and slab construction, hydraulic accessories for industrial hydraulics (mobile and stationary use).

Technology Test benches / Fluid Test benches.



*SPV, SPVF directly-operated / GB / 11.11*

# KRACHT