

# KRACHT

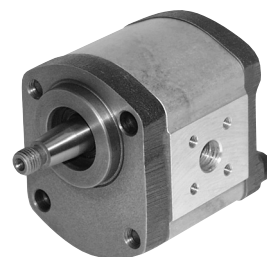

High Pressure Gear Pumps

**KP 1**

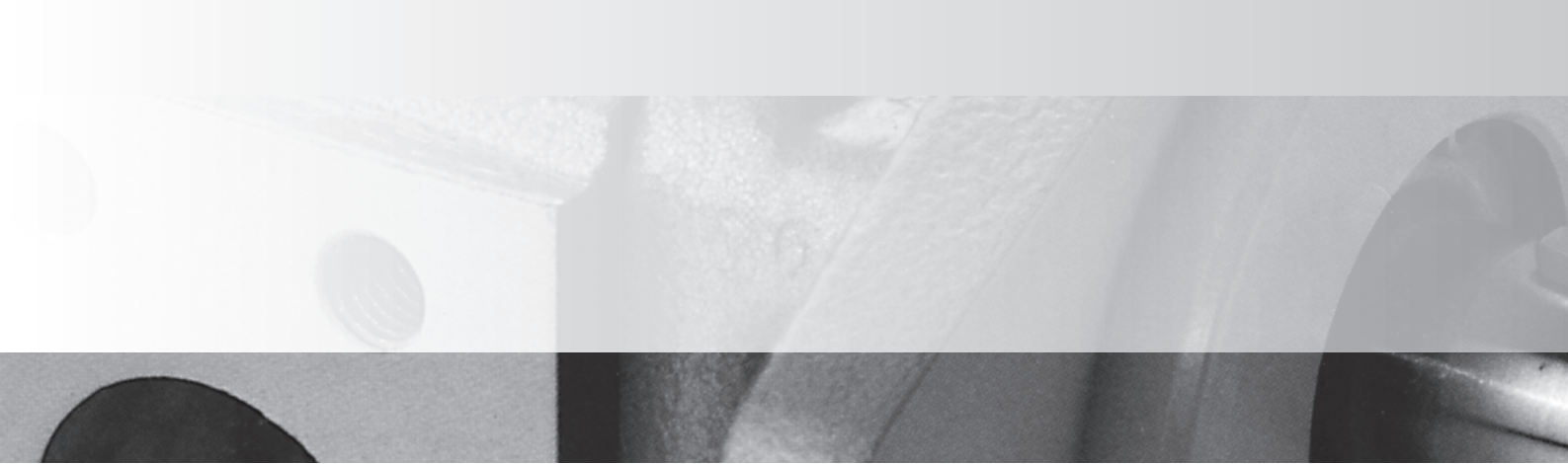

## Construction

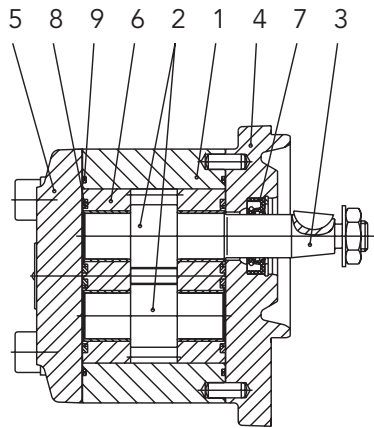

- 1 Housing
- 2 Gearing
- 3 Drive shaft end
- 4 Flange mounting cover
- 5 End cover
- 6 Double-gland bearing with special plane bearing bushes
- 7 Rotary shaft lip-type seals
- 8 Pressure field sealing for axial clearance compensation
- 9 Sealing of the housing

## Function

Accordingly to its configuration – the Design Principle is illustrated by the Sectional Figure – the KRACHT external gear type pump series KP 1 is to be classified into the category of the so-called gland type bearing pumps.

All essential functional parts as the gearing and the gland bearings are located in an aluminium housing (cast iron on request possible) manufactured of a high strength extrusion alloy which are closed on each side by an end cover or by a flange mounting cover respectively.

The gearing of case hardening steel in surface hardened condition consists of the driving shaft pinion and the driven shaft pinion.

Highest manufacturing quality is assured by grinding and honing of the tooth flanks. The surfaces of the journals are superfinished.

An important reduction of the type dependent deviation of the volumetric flow and of the pressure pulsation incident thereto was achieved on the basis of the great teeth number ( $z = 13$ ) and of the specially shaped teeth.

The gland bearings located on both sides of the gearing carry the journals in heavyduty multicomponent plane bearing bushes and contain additionally those sealing elements which serve for the pressure field sealing to compensate the axial clearance.

If required the pumps can be supplied with a Pressure Relief Valve-Type DBD... – directly attached to the pump or with special valve arrangements assembled onto the pump instead of the end cover.

Manifold pump combinations are available as well.

## Note

### 1. External loads

Loads acting on the drive shaft end from outside impair the functions of the doublegland bearing.

Radial loads can be absorbed in dependence on the extent and the direction of the loads. Axial loads are not permissible.

To absorb outer loads only those pump types shall be used which are equipped with an outboard bearing.

### 2. Direction of rotation

Regarding the direction of rotation basically the following applies provided the view is directed toward the drive shaft end:

Drive shaft end rotating clockwise:

Flow direction from left to right.

Drive shaft end rotating anticlockwise:

Flow direction from right to left.

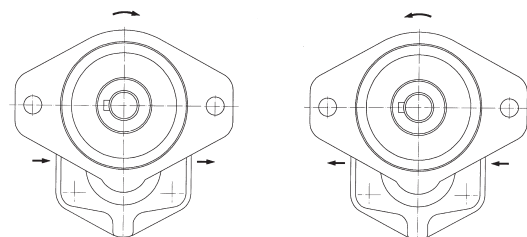

## Materials

Housing	aluminium
Bearing	double-gland bearing with multicomponent plane bearing bushes
Journals and gears	case hardening steel acc. to DIN 17210 surface hardened and ground
Seals	NBR rotary shaft lip type seal $\vartheta \leq 90^\circ\text{C}$ (PU-Seal for pressure field) FKM rotary shaft lip type seal $\vartheta \leq 100^\circ\text{C}$ (PU-Seal for pressure field)

## Characteristics

Mounting	flange and foot-type	
Pipe connection	flange type, threaded flange on request	
Direction of rotation	clockwise <b>or</b> anticlockwise	
Fitting position	optional	
Ambient temperature	$\vartheta_{u \min}$	= $-20^\circ\text{C}$
	$\vartheta_{u \max}$	= $60^\circ\text{C}$
Operating pressure Inlet port	$p_{e \min}$	= $-0.4 \text{ bar}$ ( vacuum)
	$p_{e \max}$	= $2 \text{ bar}$
Operating pressure Short time	$p_{e \max}$	= $5 \text{ bar}$
Operating pressure Outlet port	$p_{e \max}$	see technical data
Fluid temperature range	$\vartheta_{m \max}$	$90^\circ\text{C}$ for NBR rotary shaft lip type seal
	$\vartheta_{m \max}$	$100^\circ\text{C}$ for FKM rotary shaft lip type seal
Viscosity	$v_{\min}$	= $10 \text{ mm}^2/\text{s}$
	$v_{\max}$	= $600 \text{ mm}^2/\text{s}$
Recommended oil cleanliness	class 19/16 acc. to ISO/DIS 4406 ⇨ class 10 acc. to NAS 1638	
Recommended filtration	filter with filtration quotient $\beta_{25} \geq 75$ for ... 300 bar $\beta_{40} \geq 75$ for ... 100 bar	
Recommended viscosity range	$v$	= $30 \dots 45 \text{ mm}^2/\text{s}$
Discharge flow	see chart page 6	
Input power	see chart page 6	
Hydraulic fluids	mineral oil acc. to DIN 51524/25 engine oil acc. to DIN 51511 bio-oils of type „HEES“ can be used up to $70^\circ\text{C}$ , max. pressure must be reduced minus 20 % (use only on request)	

## Technical Data

Nominal displacement	Geom. displacement $V_g$ cm <sup>3</sup> /r	max. pressure $p_{max}$ bar	Rated pressure $p_N$ bar	Continuous operating pressure $p_D$ bar	max. operating speed		Moment of inertia $J$ x 10 <sup>-6</sup> kg m <sup>2</sup>	Minimum speed					
					$n_{max}$ 1/min			at $p = \dots$ bar rpm					
					NBR	FKM		...100	...120	...150	...180	...200	...250
<b>3</b>	3	300	280	250	3000	4000	23.3	600	700	900	1200	1300	1400
<b>4</b>	4	300	280	250	3000	4000	28.4	600	700	900	1200	1300	1400
<b>5.5</b>	5.45	300	280	250	3000	4000	35.7	500	700	900	1000	1200	1400
<b>6.3</b>	6.28	300	280	250	3000	4000	39.9	500	700	900	1000	1200	1400
<b>8</b>	7.9	300	280	250	3000	4000	51.1	500	700	900	1000	1100	1400
<b>11</b>	10.9	300	280	250	3000	3500	62.9	500	700	900	1000	1100	1200
<b>14</b>	13.85	300	280	250	3000	3000	77.7	500	700	800	900	1000	1100
<b>16</b>	15.9	300	280	250	3000	3000	87.7	500	600	700	800	1000	1000
<b>19</b>	18.8	250	230	200	2800	2800	102.5	500	600	700	800	1000	-
<b>22</b>	22.3	200	180	150	2500	2500	119.6	500	600	700	800	-	-

Maximum pressure = pressure peak  
 Rated pressure  $p_N < 6\text{ s} = 50\% \text{ ED}$   
 See time/pressure chart  
 max. permissible operating cycles: 30 / min  
 Pressures as specified are applicable to  $v \geq 30 \text{ mm}^2/\text{s}$

Time / pressure chart

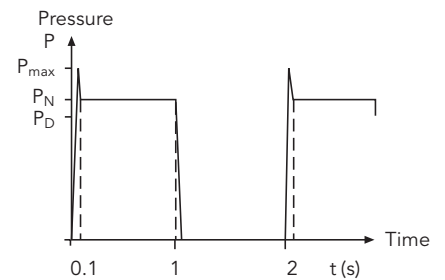

## Calculation Formulas for Hydraulic Pumps

### Characteristic data, formula signs, units

- |                                |              |                    |
|--------------------------------|--------------|--------------------|
| 1. Discharge flow / input flow | Q            | l/min              |
| 2. Pump / motor displacement   | $V_g$        | cm <sup>3</sup> /r |
| 3. Pressure                    | p            | bar                |
| 4. Speed of rotation           | n            | 1/min              |
| 5. Torque                      | M            | Nm                 |
| 6. Power                       | P            | kW                 |
| 7. Total efficiency            | $\eta_{tot}$ | —                  |
| 8. Volumetric efficiency       | $\eta_{vol}$ | —                  |
| 9. Hydr./mech. efficiency      | $\eta_{hm}$  | —                  |
| 10. Flow velocity              | v            | m/s                |
| 11. Pipe diameter              | d            | mm                 |

### General

$$Q_{th} = V_g \cdot n, \quad \eta_{tot} = \eta_{vol} \cdot \eta_{hm},$$

$$M = 9549 \cdot \frac{P}{n}, \quad v = 21.22 \cdot \frac{Q}{d^2}$$

Approximate values for KRACHT products in the nominal operating point

	$\eta_{tot}$	$\eta_{vol}$
KP	≈ 0.90	≈ 0.90

→

$n$   
 $M$   
 $P$

Pump

Characteristic data for:	Volumetric flow	Discharge flow $Q = \frac{V_g \cdot n \cdot \eta_{vol}}{10^3} \left[ \frac{l}{min} \right]$
	Torque	Drive torque $M = \frac{p \cdot V_g}{20 \cdot \pi \cdot \eta_{hm}} \text{ [Nm]}$
	Power	Input power $P = \frac{p \cdot Q}{600 \cdot \eta_{tot}} \text{ [kW]}$

## Discharge Flow and Required Input Power

### Discharge flow at n = 1450 1/min

Nominal size	Discharge flow Q in l/min at 34 mm <sup>2</sup> /s Pressure p in bar						
	20	60	100	140	180	220	260
3	4.2	4.1	4.1	4.0	4.0	3.9	3.9
5.5	7.7	7.7	7.6	7.5	7.4	7.4	7.3
8	11.2	11.2	11.1	11.0	10.9	10.8	10.7
11	15.4	15.3	15.2	15.1	15.0	14.8	14.7
14	19.6	19.5	19.4	19.3	19.2	19.0	18.9
16	22.5	22.4	22.3	22.2	22.1	22.0	21.9
19	26.7	26.6	26.5	26.4	26.3	26.2	—
22	31.6	31.5	31.4	31.4	31.3	—	—

### Required input power at n = 1450 rpm

Nominal size	Pressure p in bar						
	20	60	100	140	180	220	260
3	0.26	0.59	0.93	1.26	1.59	1.93	2.26
5.5	0.36	0.91	1.45	1.99	2.53	3.07	3.61
8	0.49	1.28	2.07	2.86	3.65	4.44	5.23
11	0.64	1.72	2.81	3.89	4.97	6.06	7.14
14	0.80	2.22	3.63	5.05	6.46	7.88	9.29
16	0.89	2.49	4.08	5.67	7.26	8.85	10.45
19	1.02	2.87	4.72	6.57	8.42	10.27	—
22	1.20	3.39	5.58	7.76	9.95	—	—

### Discharge flow at n = 950 1/min

Nominal size	Discharge flow Q in l/min at 34 mm <sup>2</sup> /s Pressure p in bar						
	20	60	100	140	180	220	260
3	2.6	2.6	2.5	2.4	—	—	—
5.5	4.9	4.8	4.6	4.5	4.4	—	—
8	7.1	7.0	6.9	6.8	6.7	—	—
11	9.8	9.7	9.6	9.5	9.4	—	—
14	12.5	12.4	12.3	12.2	12.0	—	—
16	14.3	14.2	14.1	13.9	13.8	—	—
19	17.0	16.9	16.8	16.7	16.6	—	—
22	20.1	20.0	20.0	19.9	19.8	—	—

### Required input power at n = 950 rpm

Nominal size	Pressure p in bar						
	20	60	100	140	180	220	260
3	0.18	0.39	0.60	0.82	—	—	—
5.5	0.25	0.60	0.96	1.32	1.68	—	—
8	0.33	0.85	1.37	1.89	2.40	—	—
11	0.42	1.13	1.84	2.55	3.26	—	—
14	0.52	1.41	2.31	3.20	4.09	—	—
16	0.58	1.61	2.64	3.66	4.69	—	—
19	0.68	1.89	3.11	4.33	5.55	—	—
22	0.78	2.21	3.64	5.07	6.50	—	—

## Type Key

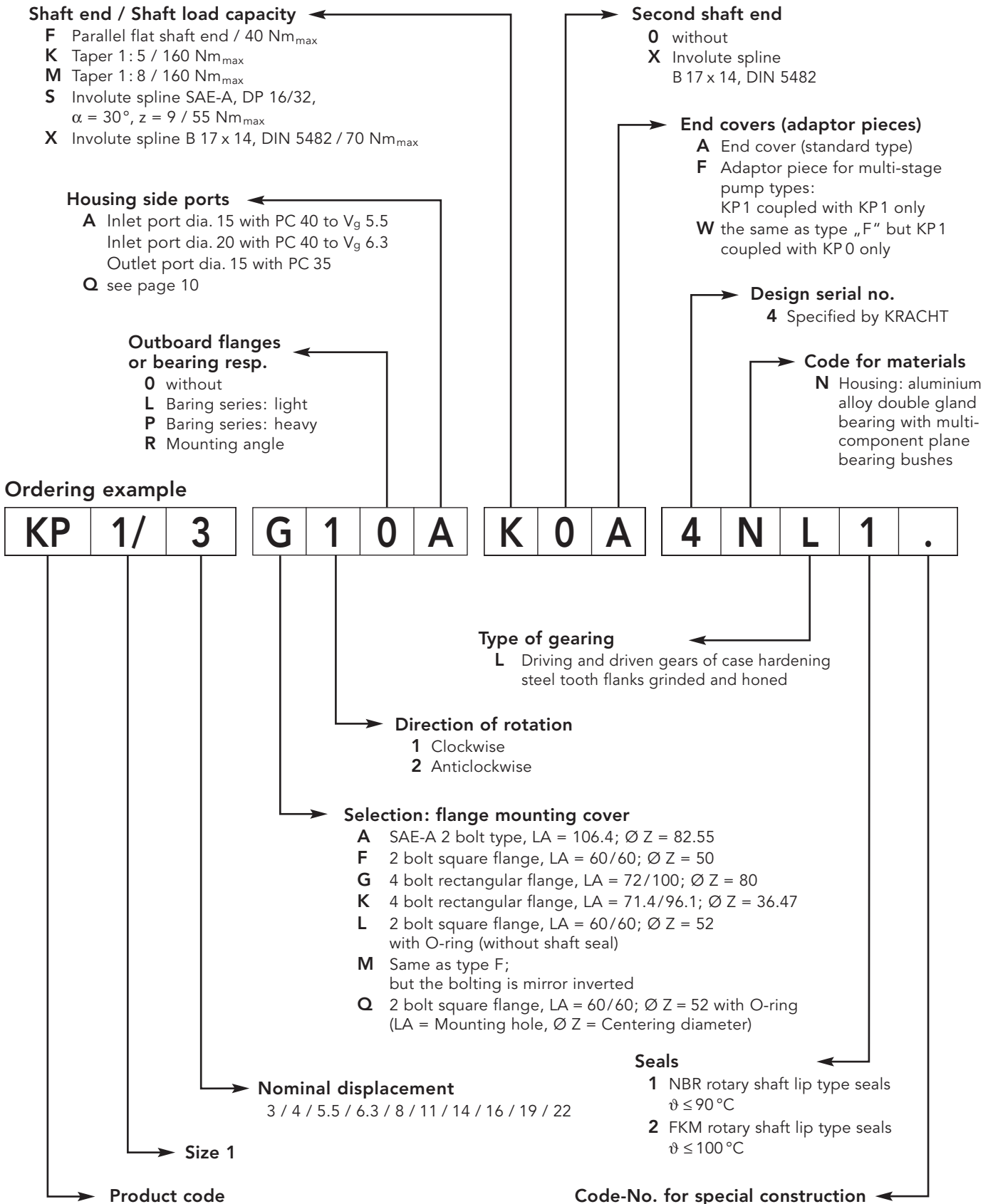



## SAE A-Flange, Tapered Shaft End

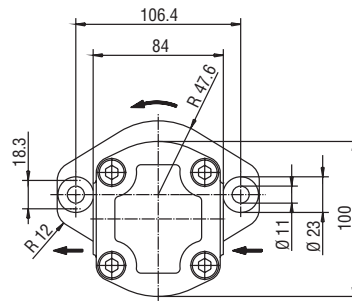
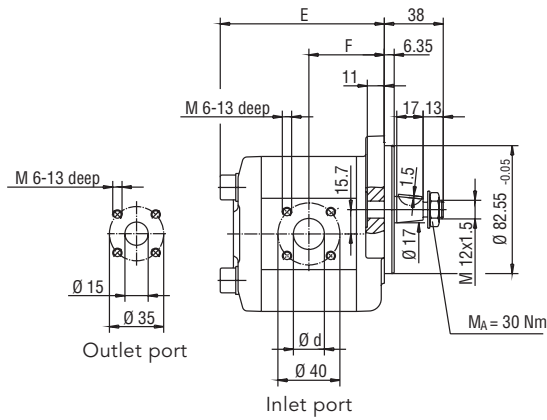

Shaft end: Taper 1:5  
 Hex. lock nut M 12 x 1.5  
 DIN EN 28675  
 Curved spring washer B 12 DIN 137  
 Woodruff key 3 x 6,5 DIN 6888

The direction of rotation as represented is clockwise  
 In case of anticlockwise rotation the inlet and outlet ports are opposite

Ordering example:  
**KP 1/4 A10A K0A 4NL1**

## SAE A-Flange, SAE A-Shaft

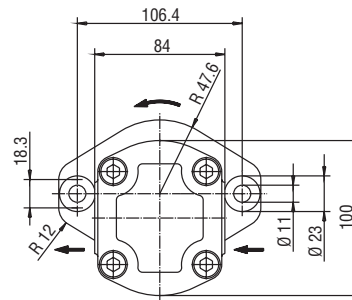
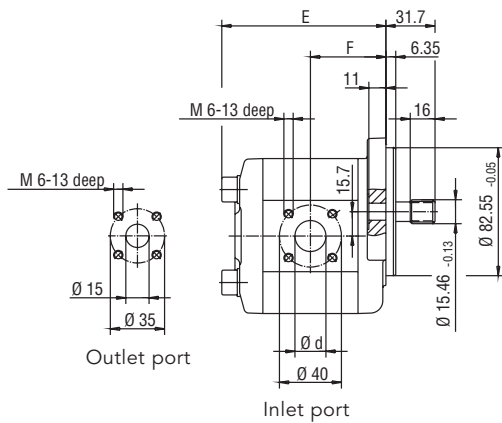

Shaft end: Involute spline  
 SAE-A z = 9 T, DP 16/32;  $\alpha = 30^\circ$

Ordering example:  
**KP 1/4 A10A S0A 4NL1**

## SAE A-Flange, Involute Spline Shaft End

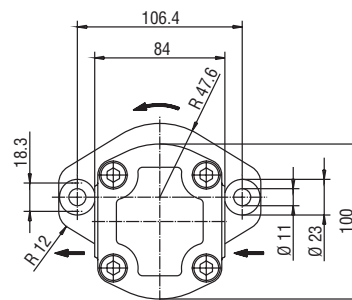
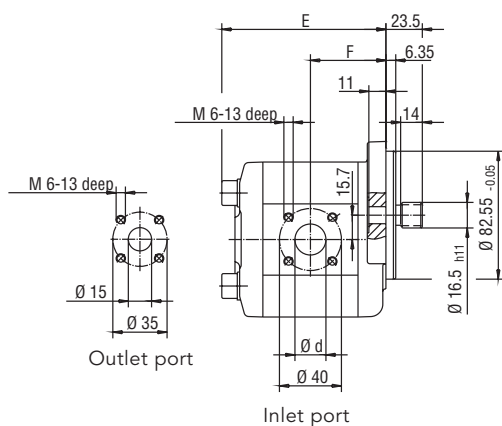

Shaft end: Involute spline  
 B 17 x 14 DIN 5482

Ordering example:  
**KP 1/4 A10A X0A 4NL1**

Nominal displacement	3	4	5.5	6.3	8	11	14	16	19	22
d	15.0	15.0	15.0	20.0	20.0	20.0	20.0	20.0	20.0	20.0
E	87.5	89.2	91.7	93.1	95.9	100.9	105.9	109.3	114.3	120.1
F	39.5	40.4	41.6	42.3	43.7	46.2	48.7	50.4	52.9	55.8
Weight kg	2.5	2.6	2.6	2.7	2.7	2.9	3.0	3.2	3.3	3.5

## K-Flange, Tapered Shaft End 1 : 8

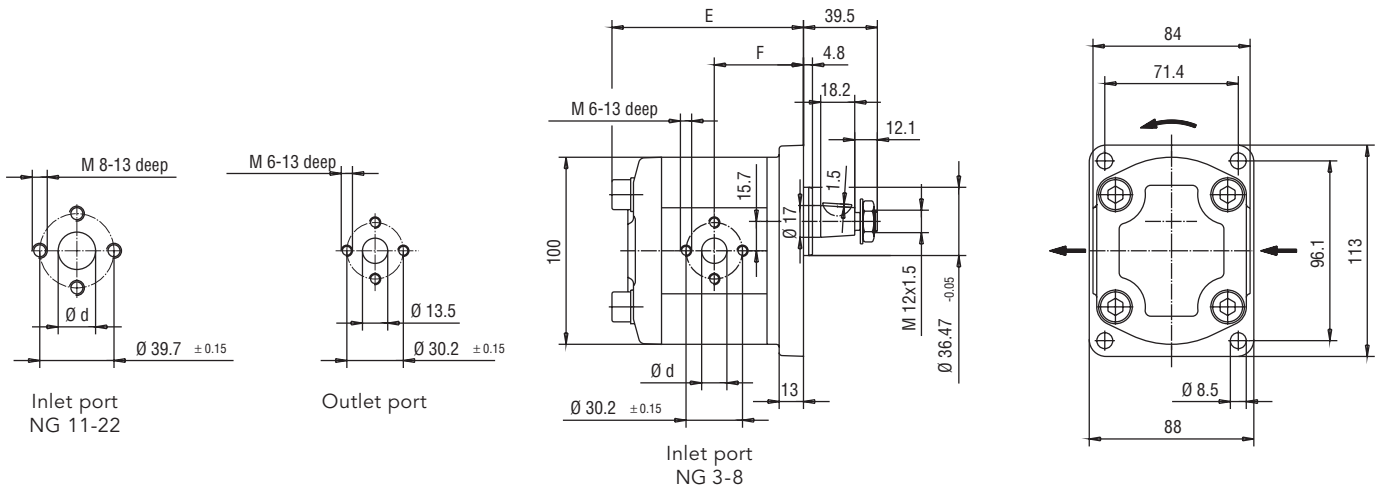

Ordering example:  
**KP 1/4 K10Q M0A 4NL1**

The direction of rotation as represented is clockwise  
 In case of anticlockwise rotation the inlet and outlet ports are opposite

Shaft end: Taper 1 : 8  
 Hex. lock nut M 12 x 1.5  
 DIN EN 28675  
 Curved spring washer B 12 DIN 137  
 Woodruff key 3 x 6.5 DIN 6888

## K-Flange, Involute Spline Shaft End

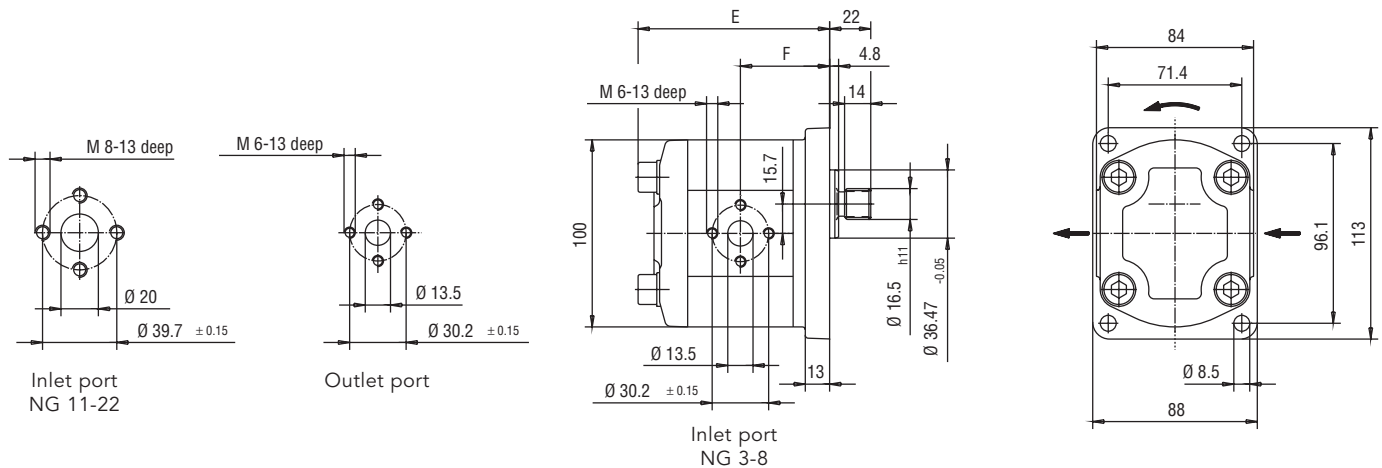

Ordering example:  
**KP 1/4 K10Q X0A 4NL1**

The direction of rotation as represented is clockwise  
 In case of anticlockwise rotation the inlet and outlet ports are opposite

Shaft end: Involute spline  
 B 17 x 14 DIN 5482  
 but tooth thickness  $S_w = 3.206$   
 Addendum modification = + 0.6

Nominal displacement	3	4	5.5	6.3	8	11	14	16	19	22
d	13.5	13.5	13.5	13.5	13.5	20.0	20.0	20.0	20.0	20.0
E	89.0	90.7	93.2	94.6	97.4	102.4	107.4	110.8	115.8	121.6
F	41.0	41.85	43.1	43.8	45.2	47.7	50.2	51.9	54.4	57.3
Weight kg	2.1	2.2	2.2	2.3	2.3	2.5	2.6	2.8	2.9	3.1

## F-Flange, Tapered Shaft End

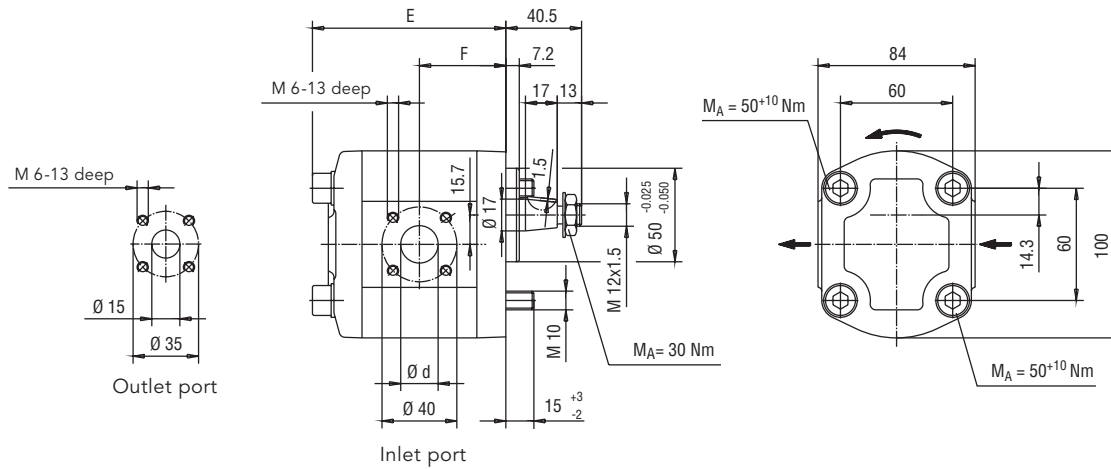

Ordering example:  
**KP 1/4 F10A K0A 4NL1**

The direction of rotation as represented is clockwise  
 In case of anticlockwise rotation the inlet and outlet ports are opposite

Shaft end: Taper 1:5  
 Hex. lock nut M 12 x 1.5  
 DIN EN 28675  
 Curved spring washer B 12  
 DIN 137  
 Woodruff key 3 x 6.5  
 DIN 6888

## F-Flange, Involute Spline Shaft End

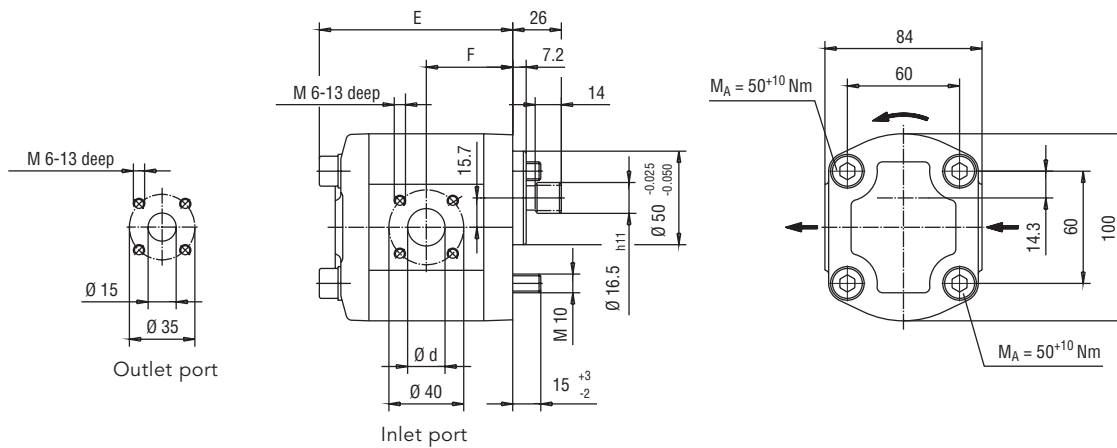

Ordering example:  
**KP 1/4 F10A X0A 4NL1**

The direction of rotation as represented is clockwise  
 In case of anticlockwise rotation the inlet and outlet ports are opposite

Shaft end: Involute spline  
 B 17 x 14 DIN 5482  
 but tooth thickness  $S_w = 3.206$   
 Addendum modification = +0.6

Nominal displacement	3	4	5.5	6.3	8	11	14	16	19	22
d	15.0	15.0	15.0	20.0	20.0	20.0	20.0	20.0	20.0	20.0
E	85.0	86.7	89.2	90.6	93.4	98.4	103.4	106.8	111.8	117.6
F	37.0	37.9	39.1	39.8	41.2	43.7	46.2	47.9	50.4	53.3
Weight kg	2.1	2.2	2.2	2.3	2.3	2.5	2.6	2.8	2.9	3.1

## M-Flange, Tapered Shaft End

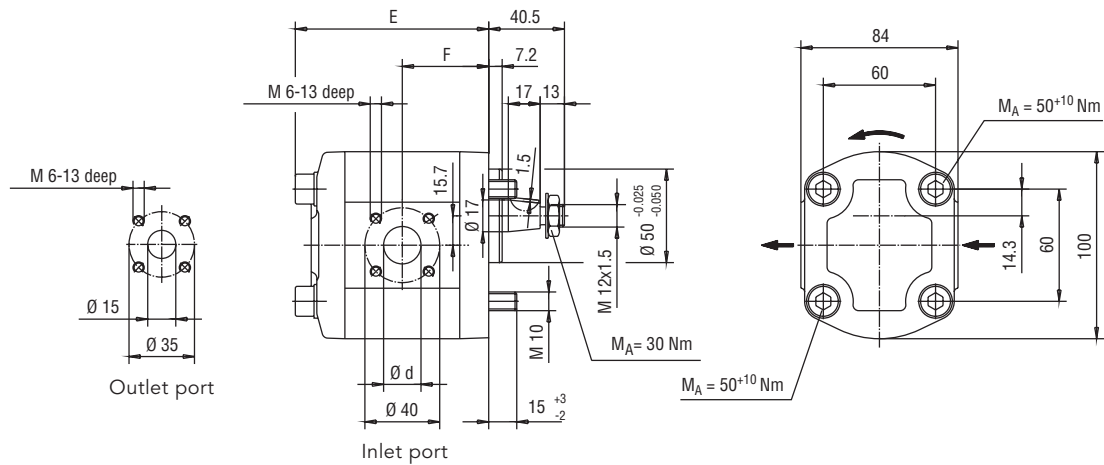

Ordering example:  
**KP 1/4 M10A K0A 4NL1**

The direction of rotation as represented is clockwise  
 In case of anticlockwise rotation the inlet and outlet ports are opposite

Shaft end: Taper 1:5  
 Hex. lock nut M 12 x 1.5  
 DIN EN 28675  
 Curved spring washer B 12  
 DIN 137  
 Woodruff key 3 x 6.5  
 DIN 6888

## M-Flange, Involute Spline Shaft End

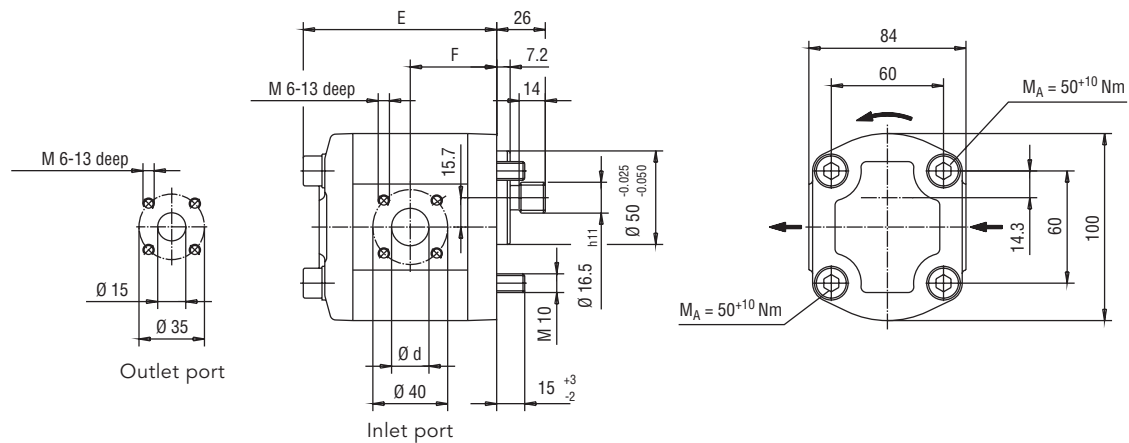

Ordering example:  
**KP 1/4 M10A X0A 4NL1**

The direction of rotation as represented is clockwise  
 In case of anticlockwise rotation the inlet and outlet ports are opposite

Shaft end: Involute spline  
 B 17 x 14 DIN 5482  
 but tooth thickness  $S_w = 3.206$   
 Addendum modification = +0.6

Nominal displacement	3	4	5.5	6.3	8	11	14	16	19	22
d	15.0	15.0	15.0	20.0	20.0	20.0	20.0	20.0	20.0	20.0
E	85.0	86.7	89.2	90.6	93.4	98.4	103.4	106.8	111.8	117.6
F	37.0	37.9	39.1	39.8	41.2	43.7	46.2	47.9	50.4	53.3
Weight kg	2.1	2.2	2.2	2.3	2.3	2.5	2.6	2.8	2.9	3.1

## Q-Flange, Tapered Shaft End

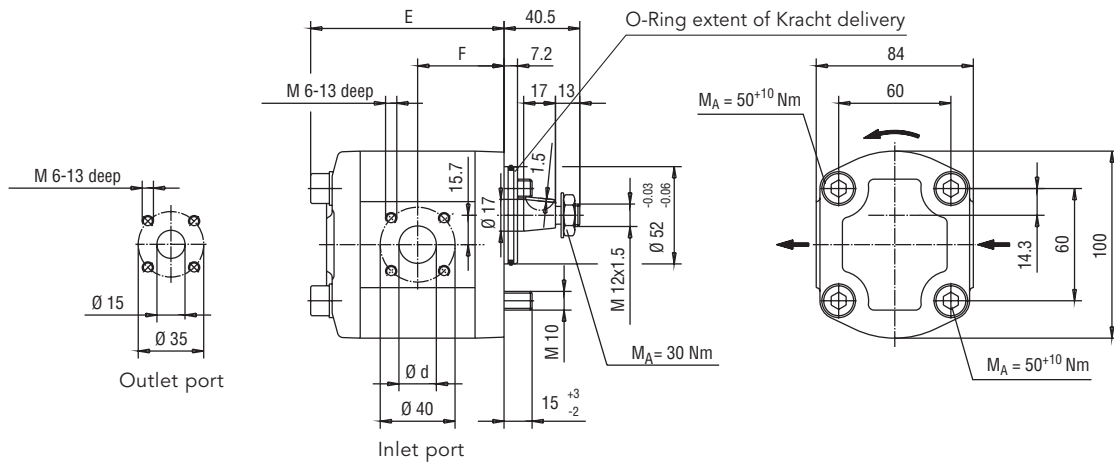

Ordering example:  
**KP 1/4 Q10A K0A 4NL1**

The direction of rotation as represented is clockwise  
 In case of anticlockwise rotation the inlet and outlet ports are opposite

Shaft end: Taper 1:5  
 Hex. lock nut M 12 x 1.5  
 DIN EN 28675  
 Curved spring washer B 12  
 DIN 137  
 Woodruff key 3 x 6.5  
 DIN 6888

## Q-Flange, Involute Spline Shaft End

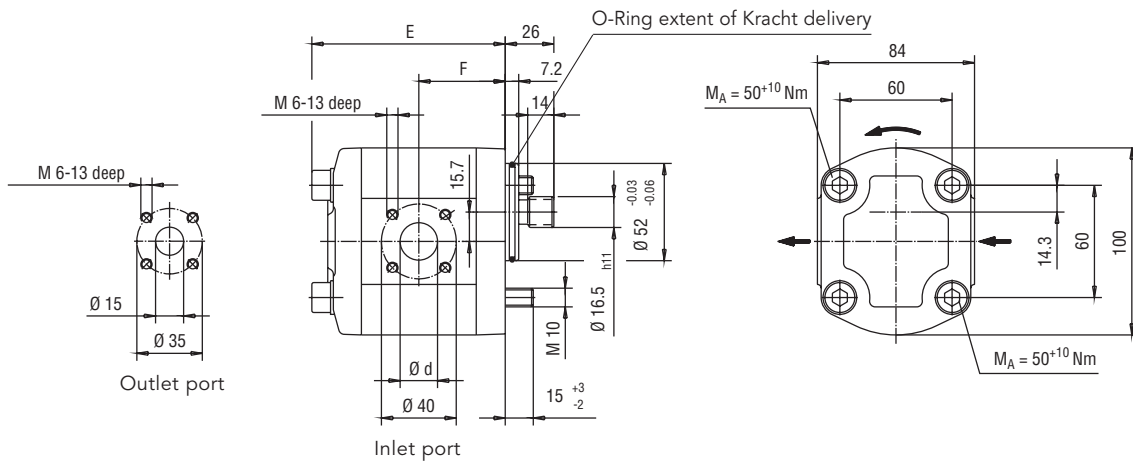

Ordering example:  
**KP 1/4 Q10A X0A 4NL1**

The direction of rotation as represented is clockwise  
 In case of anticlockwise rotation the inlet and outlet ports are opposite

Shaft end: Involute spline  
 B 17 x 14 DIN 5482  
 but tooth thickness  $S_w = 3.206$   
 Addendum modification = +0.6

Nominal displacement	3	4	5.5	6.3	8	11	14	16	19	22
d	15.0	15.0	15.0	20.0	20.0	20.0	20.0	20.0	20.0	20.0
E	85.0	86.7	89.2	90.6	93.4	98.4	103.4	106.8	111.8	117.6
F	37.0	37.9	39.1	39.8	41.2	43.7	46.2	47.9	50.4	53.3
Weight kg	2.1	2.2	2.2	2.3	2.3	2.5	2.6	2.8	2.9	3.1



## Outboard Bearing Type L, Tapered Shaft End

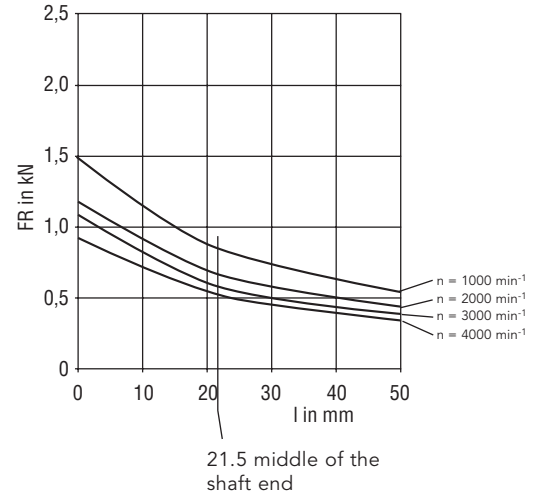
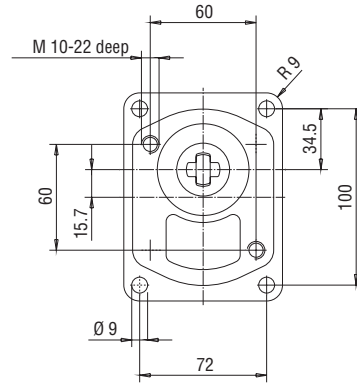
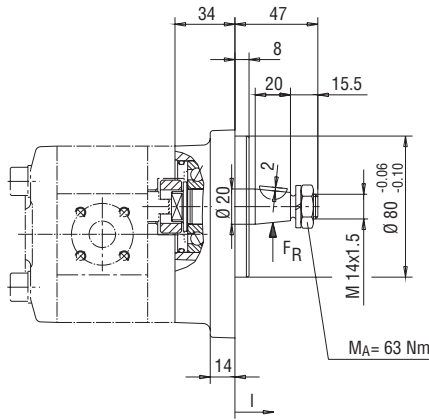

Ordering example:

**KP 1/4 L1LA F0A 4NL1**

Weight of the outboard bearing = 1.0 kg

Outboard bearing L,  
tapered shaft end KP 1/4 L1LA F0A 4NL1  
parallel flat shaft end 40 Nm<sub>max</sub>  
alternativ KP 1/4 L1LA X0A 4NL1  
Involute spline shaft end 70 Nm<sub>max</sub>

Pump dimensions and type see page 14

Shaft end: Taper 1:5  
Hex. lock nut M 14 x 1.5  
DIN EN 28675  
Curved spring washer B 14  
DIN 127  
Woodruff key 4 x 6.5  
DIN 6888

Permissible radial load  $F_R$   
as function of the supporting  
distance  $l$  (for  $L_h = 10.000$  h)  
 $F_R = f(l)$

## Outboard Bearing Type P, Tapered Shaft End

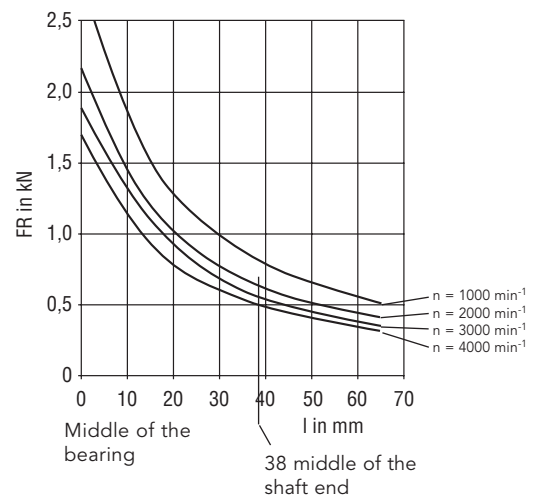
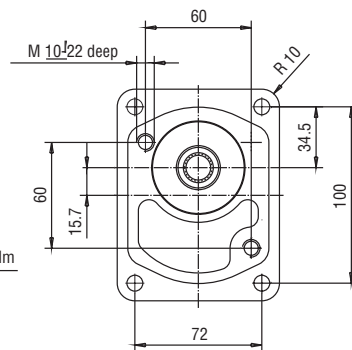
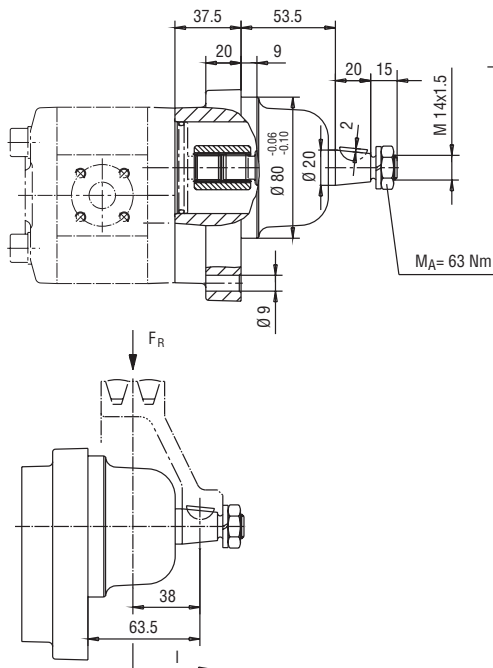

Ordering example:

**KP 1/4 Q1PA X0A 4NL1**

Shaft end: Taper 1:5  
Hex. lock nut M 14 x 1.5  
DIN EN 28675  
Curved spring washer B 14  
DIN 127  
Woodruff key 4 x 6.5  
DIN 6888

Permissible radial load  $F_R$   
as function of the supporting  
distance  $l$  (for  $L_h = 10.000$  h)  
 $F_R = f(l)$

Pump dimensions and type see page 13  
Weight of the outboard bearing = 3.5 kg

## Mounting Angle, Tapered Shaft End

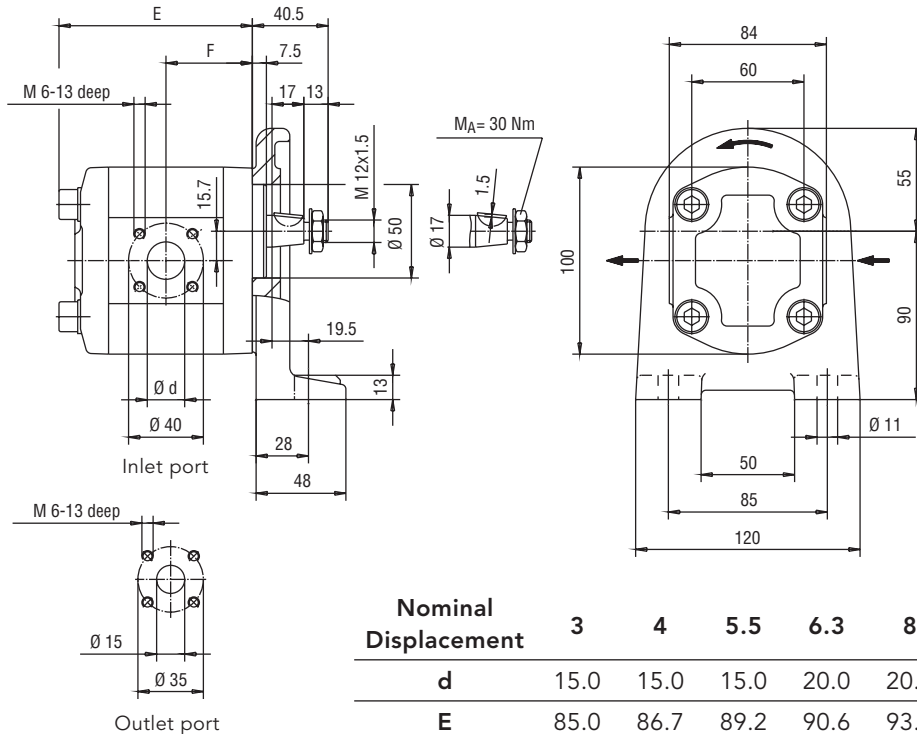

Shaft end: Taper 1:5  
 Hex. lock nut M 12 x 1.5  
 DIN EN 28675  
 Curved spring washer B 12  
 DIN 137  
 Woodruff key 3 x 6.5  
 DIN 6888

Ordering example:  
**KP 1/4 F1RA K0A 4NL1**

Nominal Displacement	3	4	5.5	6.3	8	11	14	16	19	22
d	15.0	15.0	15.0	20.0	20.0	20.0	20.0	20.0	20.0	20.0
E	85.0	86.7	89.2	90.6	93.4	98.4	103.4	106.8	111.8	117.6
F	37.0	37.9	39.1	39.8	41.2	43.7	46.2	47.9	50.4	53.3
Weight kg	3.7	3.8	3.8	3.9	3.9	4.1	4.2	4.4	4.5	4.7

## Pressure Relief Valve

- a Straight flanged connection GDA 1/12 1/16
- b Elbow flanged connection WDA 1/12 1/16

★ Fixing screws

- a Straight flanged connection 4 pieces M6 x 70 DIN 912
- b Elbow flanged connection 2 pieces M6 x 70 DIN 912  
2 pieces M6 x 85 DIN 912

Ordering code	Set pressure P <sub>v1</sub> bar	Set pressure P <sub>v2</sub> bar	Discharge flow Q <sub>1 max</sub> l/min	Discharge flow Q <sub>2 max</sub> l/min
DBD 10 D 1 A 300	10	280	15	75
DBD 10 D 1 A 200	10	200	15	70
DBD 10 D 1 A 150	10	150	10	55
DBD 10 D 1 A 85	10	85	10	45
DBD 10 D 1 A 40	10	40	10	30
DBD 10 D 1 A 16	5	16	9	20

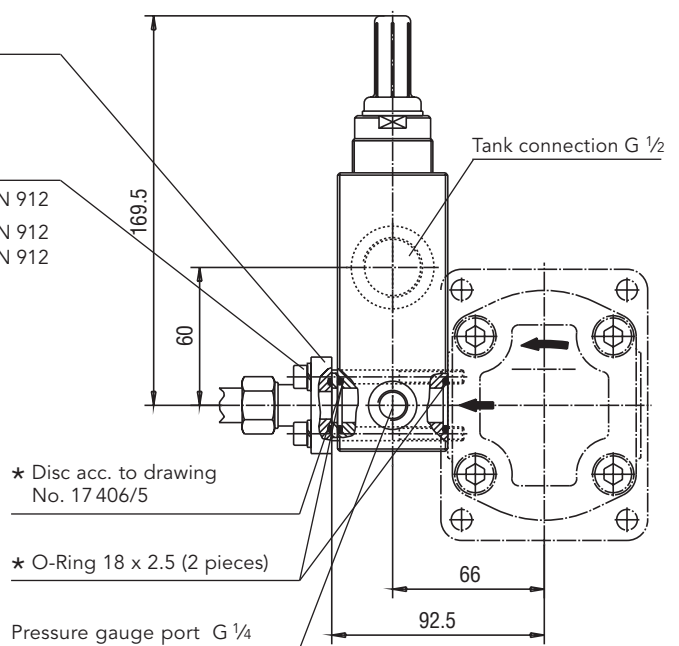

★ Disc acc. to drawing No. 17 406/5

★ O-Ring 18 x 2.5 (2 pieces)

Pressure gauge port G 1/4

★ Extent of KRACHT delivery



## Couplings and Accessories

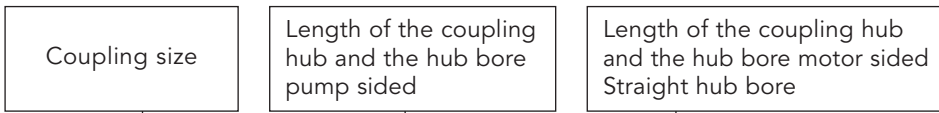
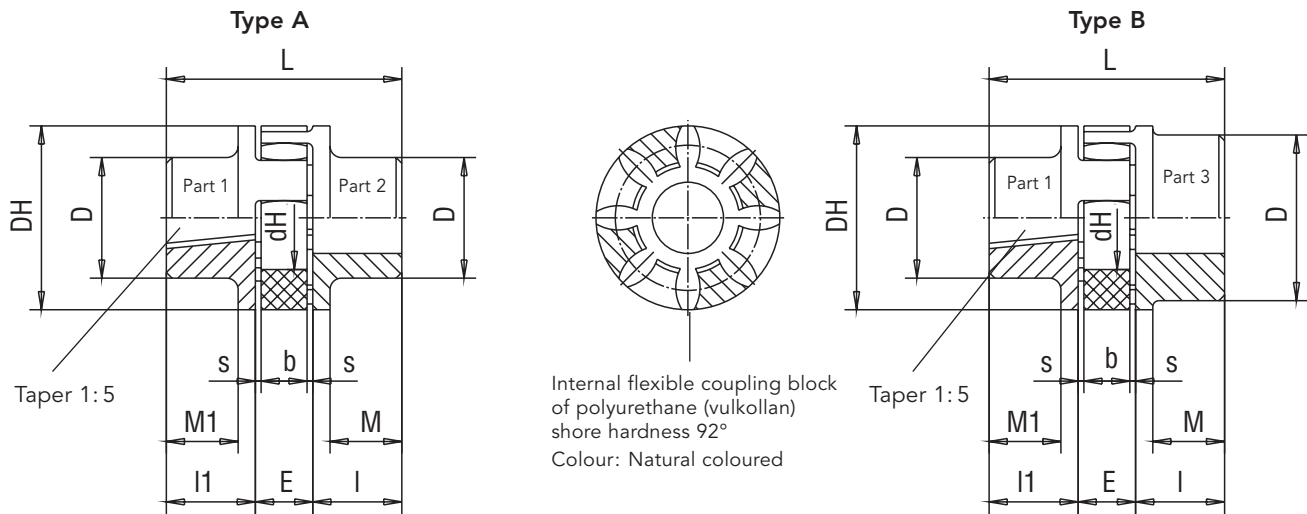

Ordering example: **RA 38 - K 18/17 - Z 45/38**

	Coupling size	Weight kg	Moment of inertia kgm <sup>2</sup>	Rough bore		Finished bore				Dimensions								Ordering code				
				Part 2	Part 3	min.		max.		l	l <sub>1</sub>	E	s	b	L	M	M <sub>1</sub>		D <sub>H</sub>	D	D <sub>1</sub>	d <sub>H</sub>
						Part 2	Part 3	Part 2	Part 3													
Type A	24	0.2	0.00008	-	-	9	-	24	-	30	18.5	18	2	14	66.5	24	12.5	55	40	-	27	RA 24-K18/17-Z 30/...
	28	0.35	0.0002	-	-	10	-	28	-	35	18.5	20	2.5	15	73.5	28	11.5	65	48	-	30	RA 28-K18/17-Z 35/...
	38	0.75	0.0007	-	-	12	-	38	-	45	18.5	24	3	18	87.5	37	10.5	80	66	-	38	RA 38-K18/17-Z 45/...
	42	1.15	0.0014	25	-	28	-	42	-	50	18.5	26	3	20	94.5	40	8.5	95	75	-	46	RA 42-K18/17-Z 50/...
Type B	24/28	0.22	0.0001	-	20	-	22	-	28	30	18.5	18	2	14	66.5	24	12.5	55	40	56	27	RA 24/28-K18/17-Z 30/...
	28/38	0.42	0.0003	-	23	-	28	-	38	35	18.5	20	2.5	15	73.5	28	11.5	65	48	67	30	RA 28/38-K18/17-Z 35/...
	38/45	0.82	0.0008	-	36	-	38	-	45	45	18.5	24	3	18	87.5	37	10.5	80	66	77	38	RA 38/45-K18/17-Z 45/...
	38/45	2.5	0.0020	-	-	-	38	-	45	70	18.5	24	3	18	112.5	62	10.5	80	66	78	38	RG 38/45-K18/17-Z 70/...
	42/55	1.29	0.0018	-	25	-	42	-	55	50	18.5	26	3	20	94.5	40	8.5	95	75	94	46	RG 42/55-K18/17-Z 50/...

Operating temperatur: - 40 °C to + 90 °C (short time temperature peaks up to + 120 °C are permissible) **RA: Hub material Al**  
 Weights as well as moments of inertia relate to the max. bore dia. after final machining – but without key-way **RG: Hub material part 2 and 3 GG**  
 Bore finish acc. to ISO-fit class H7; key-ways acc. to DIN 6885 / part 1

### Coupling sleeve

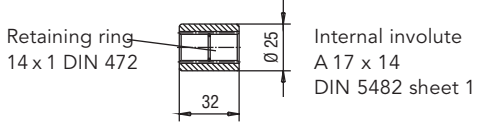

Coupling sleeve part 1  
Partnumber: B.0079020001

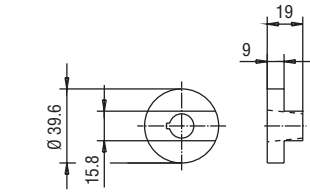

Coupling KP1 K-shaft  
Partnumber: E.0187220001

### Coupling

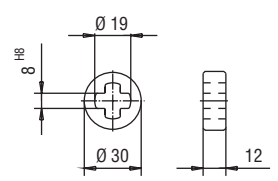

Coupling KP1 L  
Partnumber: E.0104040001

## Straight Flanged Connector

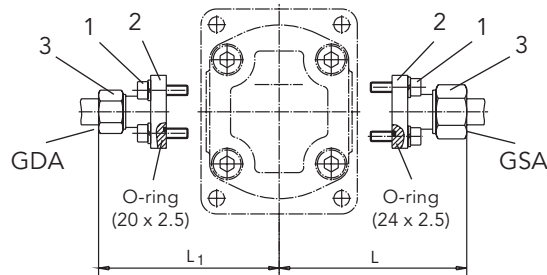

- 1 Hex. socket head cap screw (DIN 912 – 8.8)
- 2 Single coil spring lock washer (A6 DIN 127)
- 3 Covering nut with cutting ring (SW)

Inlet port Pipe externa dia. mm	Ordering code	Discharge flow Q in l/min at 34 mm <sup>2</sup> /s	Dimensions		Cap screws	Weight kg
			L	SW		
22	GSA 1/22	45	86	36	4 x M6 x 22	0.23
18	GSA 1/18	30	86	32	4 x M6 x 22	0.22
15	GSA 1/15	12	85	27	4 x M6 x 22	0.19

Outlet port Pipe externa dia. mm	Ordering code	Rated pressure P <sub>N</sub> in bar	Dimensions		Cap screws	Weight kg
			L <sub>1</sub>	SW		
16	GDA 1/16	315	82	30	4 x M6 x 22	0.18
15	GDA 1/15	250	81	27	4 x M6 x 22	0.17
12	GDA 1/12	315	81	22	4 x M6 x 22	0.16

## Elbow Flanged Connector

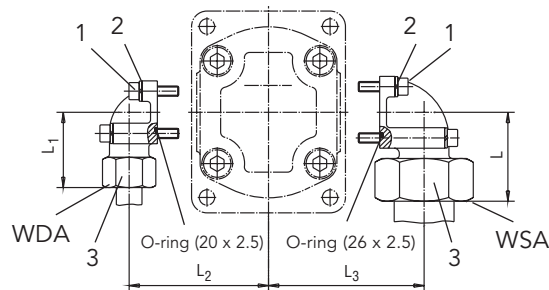

Ordering Code of a complete connection:

For the inlet port:

Straight flanged connector **GSA 1/22**

For the outlet port:

Elbow flanged connector **WDA 1/20**

Extend of Kracht delivery: Hex. socket head cap screw acc. to DIN 912 as well as single coil spring lock washers and O-rings.

Inlet port Pipe externa dia. mm	Ordering code	Discharge flow Q in l/min at 34 mm <sup>2</sup> /s	Dimensions			Cap screws		Weight kg
			L	L <sub>3</sub>	SW			
35	WSA 1/35	65	52	74	50	2 x M6 x 60	2 x M6 x 22	0.55
28	WSA 1/28	45	49	70	41	2 x M6 x 50	2 x M6 x 20	0.38
22	WSA 1/22	25	47	64.5	36	4 x M6 x 22		0.27
18	WSA 1/18	18	47	64.5	32	4 x M6 x 22		0.25
15	WSA 1/15	12	46	64.5	27	4 x M6 x 22		0.23

Outlet port Pipe externa dia. mm	Ordering code	Rated pressure P <sub>N</sub> in bar	Dimensions			Cap screws		Weight kg
			L <sub>1</sub>	L <sub>2</sub>	SW			
20	WDA 1/20	315	56	67	36	2 x M6 x 45	2 x M6 x 22	0.40
16	WDA 1/16	315	48	62	30	2 x M6 x 40	2 x M6 x 22	0.28
15	WDA 1/15	250	46	58.5	27	2 x M6 x 35	2 x M6 x 22	0.22
12	WDA 1/12	315	47	58.5	22	2 x M6 x 35	2 x M6 x 22	0.20

## Aluminium Bell Housing for KP 1/..G.-Type

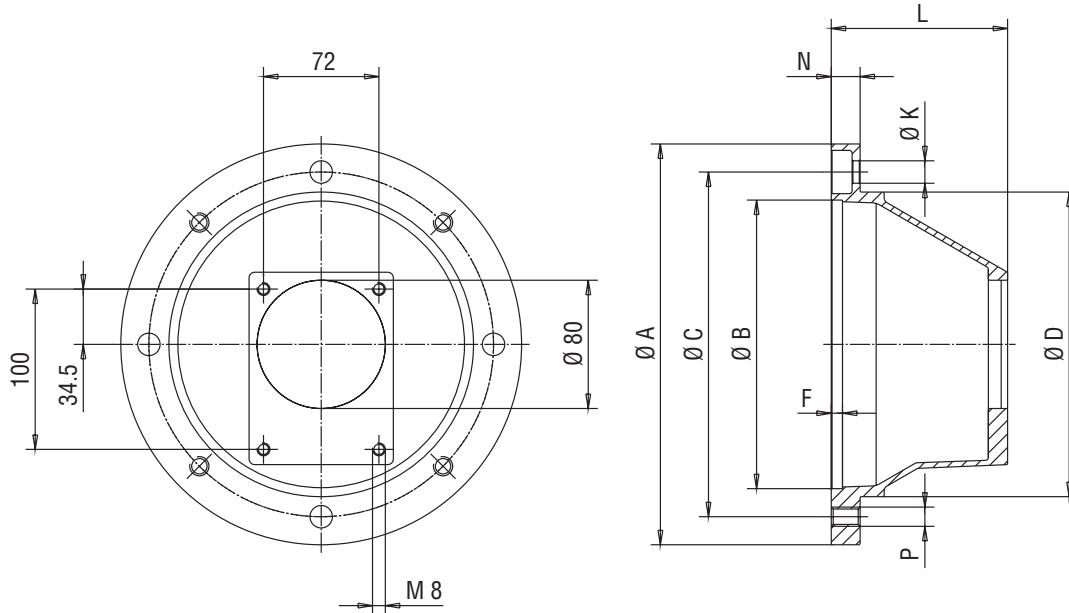

Type	Motor size											Adaptor flange weight kg	Coupling size	
	E-motor	A	B	C	D	F	K	L	N	P				
* Z1/160/111	71	160	110	130	110	7	9	110	13	9	0.8	RG24	-K18/17-Z60/14	
* Z1/200/ 90	80	200	130	165	145	7	11	90	16	M10	0.9	RA24	-K18/17-Z30/19	
* Z1/200/100	90	200	130	165	145	7	11	100	16	M10	1.0	RA24	-K18/17-Z30/24	
Z1/250/110	100/112	250	180	215	190	7	14	110	18	M12	1.5	RA24/28	-K18/17-Z30/28	
Z1/300/132	132	300	230	265	234	7	14	132	20	M12	2.1	RA38	-K18/17-Z45/38	
Z1/350/171	160	350	250	300	260	7	18	171	25	M16	3.1	RG38/45	-K18/17-Z70/42	

Those adaptor flanges marked by \* are not suitable for installations into reservoirs because the pump flange dia. is larger than the centering dia. of the adaptor flange.

Bell housing with vent hole or leakage oil-hole on request.

## Motor-Pump Assemblies KP 1 / . G.0A K0A 4 NL.

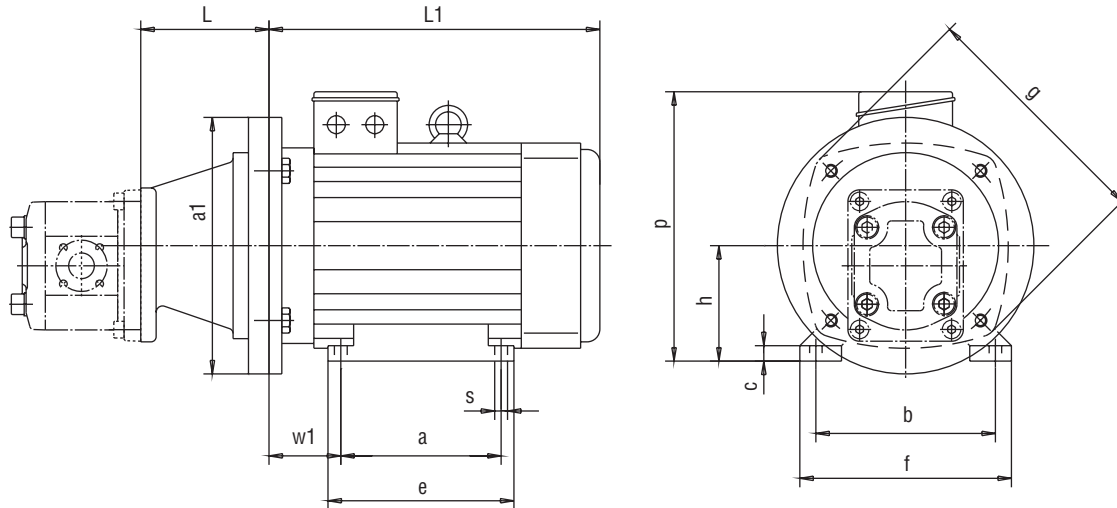

Nominal size	Power Motor 6-pole kW	Operating speed rpm	Power Motor 4-pole kW	Operating speed rpm	Bell-housing	Coupling	Weight E-motor kg		Bell-housing kg
							6-pole	4-pole	
<b>80 S</b>	0.37	920	0.55	1400	Z1/200/90-K	RA 24-K18/17-Z30/19	11	10	0.9
<b>80</b>	0.55	910	0.75	1400			12	11	
<b>90 S</b>	0.75	925	1.1	1410	Z1/200/100-K	RA 24-K18/17-Z30/24	13	13	1.0
<b>90 L</b>	1.1	935	1.5	1420			17	15	
<b>100 LS</b>	—	—	2.2	1420	Z1/250/110-K	RA 24/28-K18/17-Z30/28	—	21	1.5
<b>100 L</b>	1.5	940	3	1430			20	24	
<b>112 M</b>	2.2	945	4	1440			29	31	
<b>132 S</b>	3	955	5.5	1445	Z1/300/132-K	RA 28/38-K18/17-Z35/38	36	39	2.1
<b>132 M</b>	4	960	7.5	1450			63	60	
<b>160 M</b>	7.5	960	11	1450	Z1/350/171-K	RG 38/45-K18/17-Z70/42	76	76	3.1
<b>160 L</b>	11	960	15	1450			94	90	

Nominal size	Dimensions in mm											
	L	a <sub>1</sub>	a	b	c	e	g	h	L <sub>1</sub>	p	s	w <sub>1</sub>
<b>80 S</b>	90	200	100	125	5	120	156	80	244	199	10	50
<b>80</b>	90	200	100	125	5	120	156	80	244	199	10	50
<b>90 S</b>	100	200	100	140	12	158	190	90	258	210	9	56
<b>90 L</b>	100	200	125	140	12	158	190	90	258	210	10	56
<b>100 LS</b>	110	250	140	160	12	172	213	100	298	232	12	63
<b>100 L</b>	110	250	140	160	12	172	213	100	298	232	12	63
<b>112 M</b>	110	250	140	190	12	172	234	112	325	252	12	70
<b>132 S</b>	132	300	140	216	12	187	265	132	358	283	12	89
<b>132 M</b>	132	300	178	216	12	218	298	132	399	303	12	89
<b>160 M</b>	171	350	210	254	16	306	323	160	476	341	15	108
<b>160 L</b>	171	350	254	254	16	306	323	160	476	341	15	108

Motor frame sizes are based on Schäfer. Other manufactures motors can be supplied on request as IM B 35.





# Product Portfolio

## Transfer Pumps

Transfer pumps for lubricating oil supply equipment, low pressure filling and feed systems, dosing and mixing systems.

## Mobile Hydraulics

Single and multistage high pressure gear pumps, hydraulic motors and valves for construction machinery, vehicle-mounted machines.

## Flow Measurement

Gear and turbine flow meters and electronics for volume and flow metering technology in hydraulics, processing and laquering technology.

## Industrial Hydraulics / Test Bench Construction

Cetop directional control and proportional valves, hydraulic cylinders, pressure, quantity and stop valves for pipe and slab construction, hydraulic accessories for industrial hydraulics (mobile and stationary use).

Technology Test benches / Fluid Test benches.



KP 1 / GB / 11.08

# KRACHT